

Technical Information

Soliwave FDR16/FQR16

Microwave barrier



Ultra-compact microwave barrier for non-contact point level detection

Application

- Point level switch for all kinds of bulk solids and liquids, for counting piece goods, also in explosive areas
- Process temperature range: -20 to +450 °C (-4 to +842 °F) with optional high temperature adapter
- Process pressure range: 0.5 to 21 bar (7 to 305 psi) absolute with optional high pressure adapter
- Non-contact detection: use in containers, pipelines, shafts or free-fall shafts (detection from the outside is possible for non-metallic container materials)

Your benefits

- Ultra-compact devices with integrated power supply and connectors
- Easy mounting using G1, G1½ or 1½ NPT thread or a suitable mounting adapter
- Adjustable sensitivity and switching delay
- Detection even with changing product properties
- Use even in difficult-to-access or confined installation conditions
- Function control on site via LED indication
- Robust stainless steel housing
- Simple and cost-effective commissioning
- Meets the requirements of EU 1935/2004
- DC-PNP power amplifier

Table of contents

About this document	3	Mechanical construction	20
Symbols	3	Dimensions	20
Function and system design	4	Weight	20
Measuring principle	4	Materials	21
Measuring system	5	Process connection	21
Input	5	Operability	21
Measured variable	5	Operation concept	21
Measuring range (Detection range)	5	On-site operation	23
Operating frequency	6	Function test	24
Transmitting power	6	Certificates and approvals	24
Antenna opening angle (3 dB)	6	CE mark	24
Output	6	Ex approval	24
Switching output	6	RoHS	24
Ex connection data	6	Telecommunications	24
Power supply	6	Food suitability	24
Supply voltage	6	Ordering information	24
Power consumption	6	TAG	24
Current consumption	6	Scope of delivery	25
Electrical connection	6	Preset switching delay	25
Load	7	Accessories	25
Potential equalization	7	Prefabricated cables	25
Ex connection data	7	Operating magnet	27
Device connector	7	Counternut	27
Connecting cable	8	Mounting bracket	27
Performance characteristics	8	Welding sleeve	28
Reference conditions	8	Weld-in adapter	28
Influence ambient temperature	8	Mounting flange	28
Vibration influence	8	High pressure adapter	30
Mounting	8	Plug	30
Mounting location	8	Sight glass fitting	31
Mounting position	8	Insertion adapter	32
Alignment notes	9	Weld-in nozzle	33
Optimization of the signal quality	9	High temperature adapter with extension	33
Reflector operation	10	Supplementary documentation	34
Parallel operation	10	Device-dependent supplementary documentation	34
Installation instructions	11		
Mounting in contact with the process	11		
Mounting samples	12		
Mounting not in contact with the process	13		
Environment	19		
Ambient temperature	19		
Storage temperature	19		
Degree of protection	20		
Vibration resistance	20		
Electromagnetic compatibility	20		
Reverse polarity protection	20		
Process	20		
Process temperature	20		
Process pressure	20		
Vibration	20		

About this document

Symbols

Safety symbols



This symbol alerts you to a dangerous situation. Failure to avoid this situation will result in serious or fatal injury.



This symbol alerts you to a dangerous situation. Failure to avoid this situation can result in serious or fatal injury.



This symbol alerts you to a dangerous situation. Failure to avoid this situation can result in minor or medium injury.



This symbol contains information on procedures and other facts which do not result in personal injury.

Electrical symbols

Ground connection

Grounded clamp, which is grounded via a grounding system.

Symbols for certain types of information



Permitted
Procedures, processes or actions that are permitted.



Forbidden
Procedures, processes or actions that are forbidden.



Tip
Indicates additional information



Reference to documentation



Reference to another section



Reference to graphic

1., 2., 3. Series of steps

Symbols in graphics

A, B, C ... View

1, 2, 3 ... Item numbers

Device-specific symbols



LED on
Indicates an illuminated LED



LED off
Indicates a non-illuminated LED



LED undefined
Indicates an undefined or arbitrary light state of the LED



Free path
Indicates the free path between FDR and FQR



Covered path
Indicates the covered path between FDR and FQR

Function and system design

Measuring principle

The Soliwave FQR16/FDR16 is a microwave barrier for point level detection, which operates according to the transmitter-receiver principle. It emits microwaves which are attenuated by the medium to be detected. The received microwave signal is evaluated and a corresponding output signal (two switching outputs, DC-PNP) is generated.

The microwave barrier is typically used for notification when containers, silos or similar are full and/or empty. Full notification is used to protect against overflow while empty notification is used, for example, to protect downstream conveyor devices from running dry.

The microwave barrier can also be used for object detection as well as for control and counting purposes.

Due to the ultra-compact design, the microwave barrier can also be used at measuring points with very limited space.

- i
 - The range of the microwave signal is influenced by the different types of materials. The attenuation is dependent on the electrical properties of the damping material. Materials with the capacity to conduct electricity, such as metals, reflect the waves, while other materials with lower conductivity only weaken them or are even penetrated.
 - The attenuation of the microwaves is reduced as the damping of the material to be permeated is lower.
 - The FQR16/FDR16 device types (with G1½ or 1½ NPT process connection) are mechanically compatible to the FQR50/FDR50, FQR56/FDR56 and FQR57/FDR57, the same process adapter can be used for all types.
 - The FQR16/FDR16 device type is electrically incompatible to the FQR50/FDR50, FQR56/FDR56 and FQR57/FDR57.

Example min/max point level detection of a vessel

With the help of two microwave barriers, the overshoot of the upper (e.g. product overflow) and the undercut of the lower point level value (e.g. dry running of the discharge screw conveyor) can be detected safely.

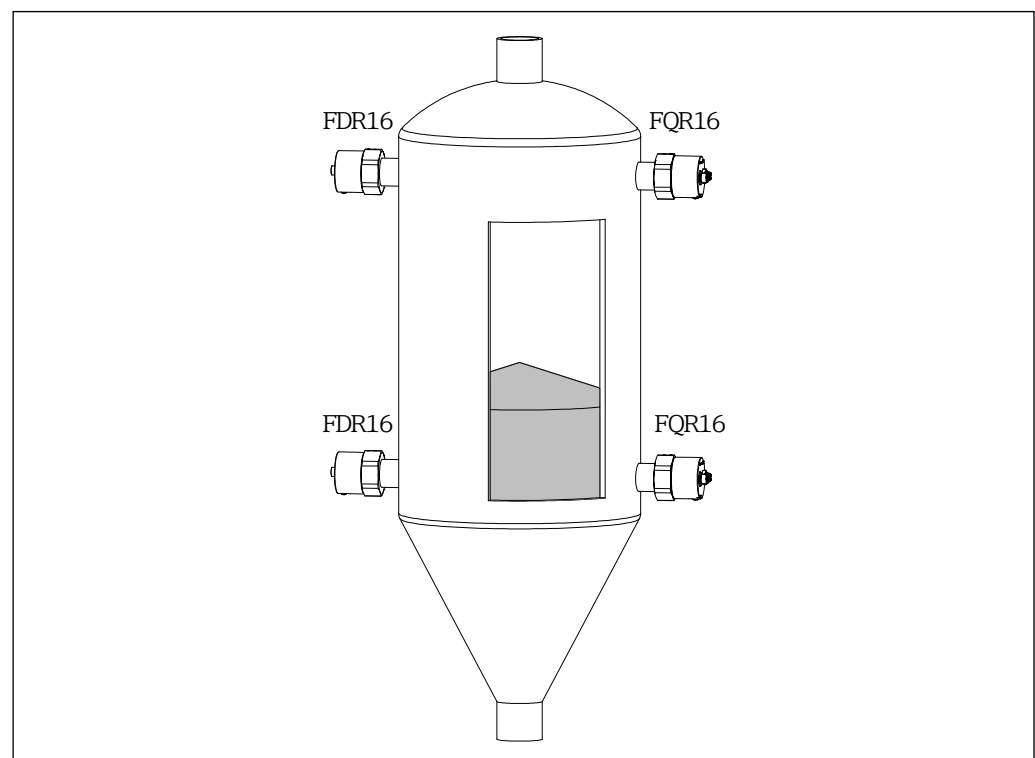

1 Example min/max point level detection

000000001

Example counting piece goods

The microwave barrier detects piece goods reliably, even under dusty conditions. As the piece goods are being transported on a conveyor belt with a certain distance between them, their quantity can be determined through evaluation of the relay output (switches once for each piece good).

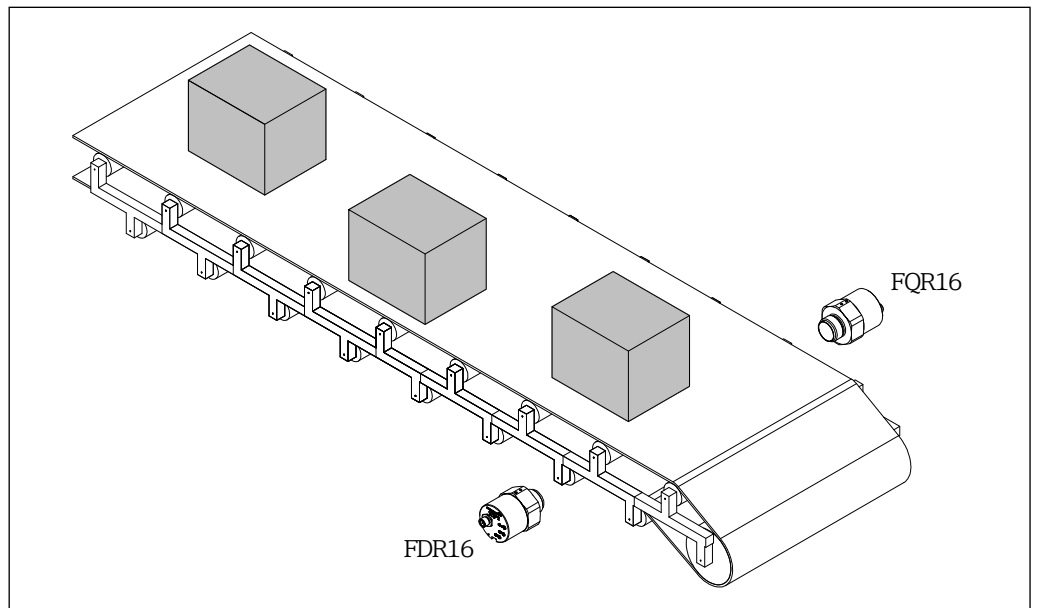

2 Example counting piece goods

000000002

i For optimum mounting on the process, the device can be extended with appropriate accessories such as weld-in nozzles, sight glasses or high temperature adapters for process separation.
→ 25

Measuring system

The complete measuring system consists of the devices FDR16 and FQR16 of the microwave barrier Soliwave, e.g. for connection to programmable logic controllers (PLC).

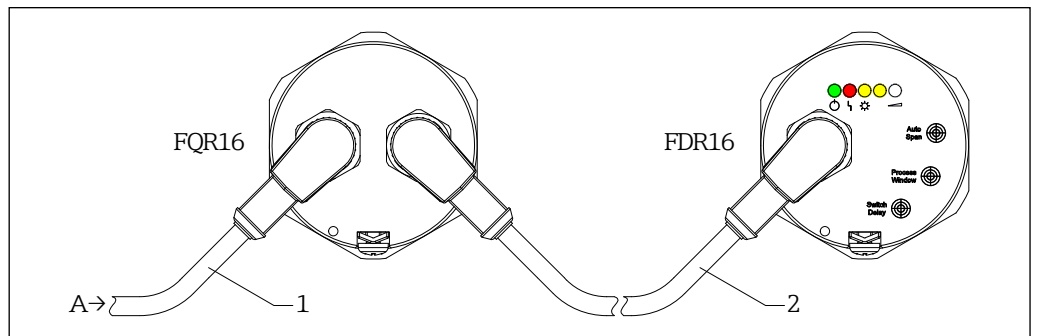

3 Measuring system

000000004

- A Supply and signal circuit
- 1 Connection cable M12 socket
- 2 Connection cable M12 socket/plug

Input

Measured variable

Absorption of the radiated electromagnetic waves

Measuring range (Detection range)

- With free path between FQR16 and FDR16, the maximum range is 20 m (787.4 in).
- The range also depends on the container walls to be penetrated.

Operating frequency 24.15 to 24.25 GHz

Transmitting power The radiated power is maximum 100 mW e.i.r.p. (equivalent isotrope radiation performance).

- Power density directly in front of the device: Approx. 1 mW/cm²
- Power density at a distance of 1 m: Approx. 0.3 μW/cm²

 The power density is clearly below the recommended limit values of the ICNIRP guidelines "Guidelines for Limiting Exposure to Time-Varying Electric, Magnetic, and Electromagnetic Fields (up to 300 GHz)" and thus is completely harmless for humans.

Antenna opening angle (3 dB) Approx. ± 12°

Output

Switching output



- 3-wire DC-PNP (positive voltage signal at the switching output of the electronics)
- 2 DC-PNP outputs, antivalent switched
- Max. 200 mA per output, short-circuit proof
- Switching delay parameterizable (off, 500 ms to 10 s)
- Safety-related circuit: MIN or MAX point level: The electric switch opens when the point level is reached, in case of malfunctions or power failure.
 - Maximum point level detection (MAX): e.g. for overflow protection
The microwave barrier keeps the electrical switch closed as long as the beam path is **free**.
 - Minimum point level detection (MIN): e.g. for no-load protection
The microwave barrier keeps the electrical switch closed as long as the beam path is **covered**.

Ex connection data See safety instructions (XA): All data relating to explosion protection are provided in separate Ex documentation and are available from the Downloads Area of the Endress+Hauser-website. The Ex documentation is supplied as standard with all Ex devices.

Power supply

Supply voltage

- U = 18 to 30 V DC
- In accordance with IEC/EN61010 a suitable circuit breaker must be provided for the measuring device.
- Voltage source: Non-hazardous contact voltage or Class 2 circuit (North America).

 ▪ The power supply of the FDR16 is provided by the FQR16. →  5

- The devices are internally equipped with a fine-wire fuse 500 mA (slow-blow) according to IEC 60127-2, this cannot be changed by the user in the event of a fault.

Power consumption $P \leq 2.4 \text{ W}$

Current consumption $I \leq 120 \text{ mA}$ (without load)

Electrical connection

- The electrical connection is made via M12 connectors. →  5
- Suitable connection cables for use in hazardous and nonhazardous areas are available as accessories. →  25

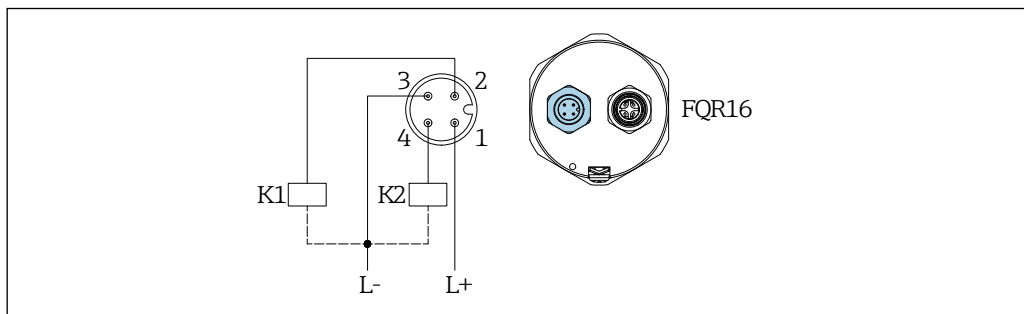

4 Electrical connection

000000006

Kx External load

Point level	Signal strength (LED white)	Sensor state	Switching output	
			MAX safety	MIN safety
	LED on or flashing fast (approx. 9 to 15 Hz)			
	LED off or flashing slowly (approx. 2 to 8 Hz)			

Function test

With a two-channel evaluation, a function monitoring of the microwave barrier can be realized in addition to the point level detection.

When both outputs are connected, the MIN and MAX outputs assume opposite states (antivalence) in fault-free operation. In the event of a fault or a line break, both outputs drop out.

Point level	Sensor state	Error/Warning	Switching output	
		Warning LED flashing		
		Error LED lights up permanently		

Load

Max. 200 mA

Potential equalization

Requirements:

- The potential equalization must be connected to the external ground terminal on the device.
- For optimum electromagnetic compatibility, keep the potential equalization line as short as possible.
- The recommended cable cross-section is 2.5 mm².
- The potential equalization of the FDR16/FQR16 must be included in the local potential equalization.

Ex connection data

See safety instructions (XA): All data relating to explosion protection are provided in separate Ex documentation and are available from the Downloads Area of the Endress+Hauser-website. The Ex documentation is supplied as standard with all Ex devices.

Device connector



- M12-A, 4-pole
- FDR16: Built-in plug for connection to the FQR16
- FQR16:
 - Built-in plug for connecting the supply voltage and the signal outputs
 - Built-in socket for connection to the FDR16

Connecting cable	<ul style="list-style-type: none"> ▪ Connection cable FQR16 max. 2.5 Ω/core ▪ Connecting cable FDR16 with FQR16 max. 5 Ω/core ▪ Total capacity < 100 nF <p> Suitable prefabricated connection and connecting cables for the Ex-free and Ex-area are available as order variants and accessories.</p>
-------------------------	---

Performance characteristics

Reference conditions	Each application is different with regard to its geometry (such as influencing reflection edges), the medium as well as the medium properties (such as attenuation and degree of humidity) and therefore always requires an individual basic adjustment of the microwave barrier.
Influence ambient temperature	The ambient temperature has no direct influence on the device (the devices are temperature compensated internally).
Vibration influence	<p>Vibration resistance - vibration according to EN 60068-2-6</p> <ul style="list-style-type: none"> ▪ Excitation: Sine ▪ Frequency range: 5 to 500 Hz ▪ Amplitude: 5 to 15 Hz (5.5 mm) peak / 15 to 500 Hz 5 g ▪ Passing speed: 1 octave per minute ▪ Test directions: 3 directions (X, Y, Z) ▪ Test duration: approx. 140 minutes per direction (approx. 70 minutes per temperature/direction) ▪ Test temperature: -40 to +70 °C <p>Shock resistance - shock according to EN 60068-2-27</p> <ul style="list-style-type: none"> ▪ Excitation: half sine ▪ Shock duration: 18 ms ▪ Amplitude: 30 g ▪ Number of shocks: 3 per direction and temperature ▪ Test directions: 6 directions ($\pm X$, $\pm Y$, $\pm Z$) ▪ Test temperature: -40 to +70 °C

Mounting

Mounting location	<p>The mounting location must be selected in such a way that application-specific influences are minimized.</p> <p> <ul style="list-style-type: none"> ▪ Observe mechanical protection of the equipment (for example in case of larger falling pieces of product). → 25 ▪ Depending on the mounting location, different process adapters are available as accessories. </p> <p> For a device for the hazardous area: Observe the instructions in the Ex documentation (XA).</p>
Mounting position	In principle, the installation position can be any for the microwave barrier, but the FQR16 and the FDR16 must be opposite each other within the detection range (maximum angle between both devices (antenna opening angle) = 12°).

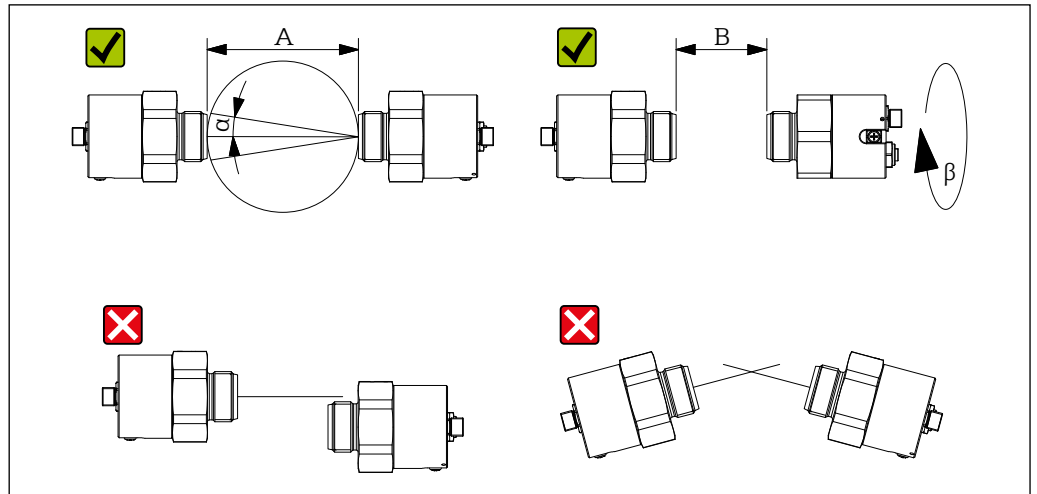

000000005

5 Mounting position

- A Detection range 0.5 to 20 m (19.7 to 787.4 in)
- B Detection range 0.12 to 0.5 m (4.7 to 19.7 in)
- α Antenna opening angle approx. 12°
- β 90°

Alignment notes

- Since the microwaves are polarized, the FQR16 and the FDR16 must not be rotated against each other about their longitudinal axis (except by 180° or for detection ranges smaller than 500 mm (19.7 in)).
- Maintain a minimum distance of 120 mm (4.7 in) between the FQR16 and the FDR16.
- **To avoid overdrive in the detection range smaller than 500 mm (19.7 in), mount the FQR16 or the FDR16 rotated by 90°.**
- To check the alignment, use the position of the potential equalization terminal; it must point in the same direction for both devices (or be rotated 90° for detection ranges smaller than 500 mm (19.7 in)).

Optimization of the signal quality

If the microwave barrier devices are installed in front of microwave-permeable windows or plugs, it is possible to optimize the signal quality by moving FQR16 and FDR16 on their longitudinal axis **after an automatic adjustment has been performed.**

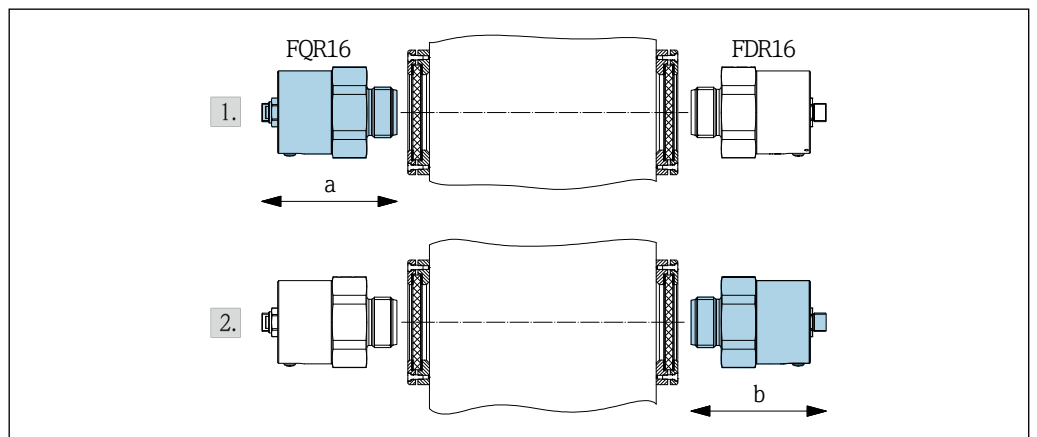

000000003

6 Optimization of the signal quality

1. Loosen device 1 (here FQR16) and move it slowly by $a = \pm 10$ mm (± 0.4 in) until a signal maximum is reached (max. flashing or permanently illuminated LED signal strength, fix device again. → 21)
2. Then loosen device 2 (here FDR16) and move it slowly by $b = \pm 10$ mm (± 0.4 in) until a signal maximum is reached, fix the device again.

- i** Perform an automatic calibration again after each change in the position of the devices (in this case, horizontal movement).

Reflector operation

If a direct comparison of FQR16 and FDR16 is not possible for structural reasons, the microwave beam can be redirected via plane metal mirrors (reflectors).

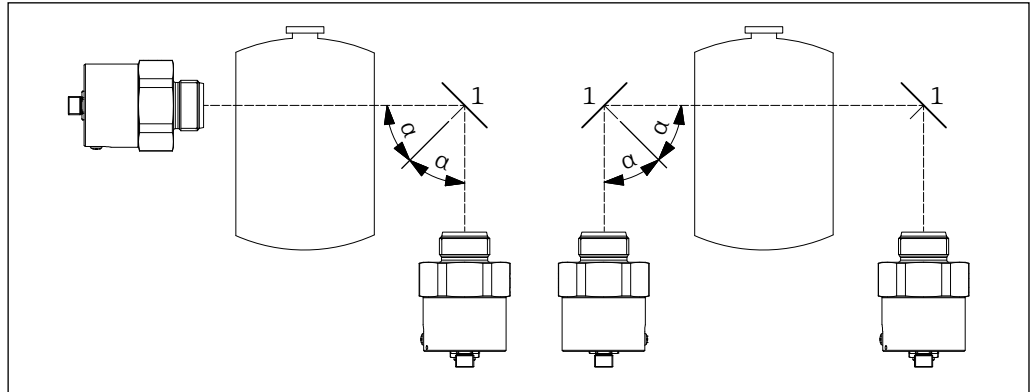

7 Reflector operation

1 Reflector

α Angle of entrance = angle of emission

- i**
- Arrange FQR16 and FDR16 symmetrically to the reflector (entrance angle = exit angle), otherwise the FDR16 will not receive an evaluable signal.
 - The use of reflectors reduces the range of the microwave barrier by approx. 10 % in each case.

Parallel operation

In practice, it can happen that several microwave barriers are operated in parallel at one point (for example, when detecting several point levels in a pipeline). To avoid mutual interference as far as possible, rotate every second microwave barrier by 90°.

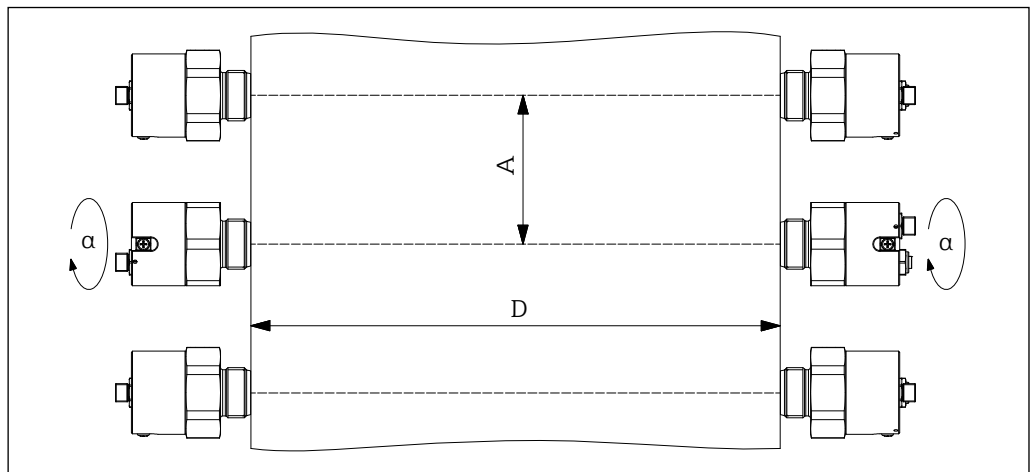

8 Parallel operation

A Distance between microwave barriers

D Detection range



α 90°

- i**
- Under ideal conditions, the distance **A** should not be less than **D/2**.
 - Increase the distance additionally in applications where stronger reflections are to be expected (e.g. metallic shafts).
 - In case of small distances between the microwave barriers, we recommend the use of the devices Soliwave FDR57/FQR57 with the Nivotester FTR525, with these a parallel operation of up to 5 barriers is possible without considering the individual distances.

Installation instructions

Basically, there are two ways to mount the FDR16 and FQR16 devices:

- Process-contact mounting: The process connection with the transmission window come into direct contact with the medium.
- Mounting not in contact with the process: The process connection with the transmission window do not come into direct contact with the medium.

-  For optimum alignment after mounting on the process, rotate the electronics housing as required (by 360°).
- Extensive accessories are available for adapting to the respective process conditions.
→  25

Mounting in contact with the process

The device is screwed directly into the process (for example in existing threads or vessel sleeves) with its process connection (standard threads G 1 and G 1½ according to ISO 228-1 or 1½ NPT according to ANSI/ASME B1.20.1).

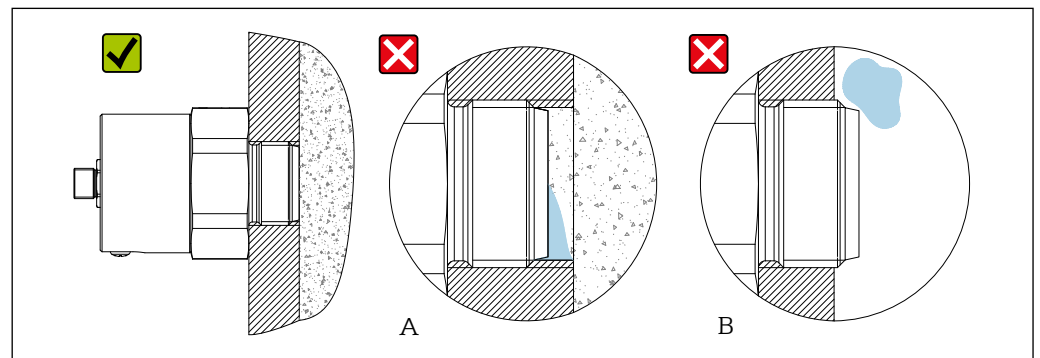

Direct mounting with threaded connection

The simplest mounting method is by screwing into the process wall. To do this, a corresponding internal thread (G 1, G 1½ or 1½ NPT) must be available in the process.



 9 Direct mounting with threaded connection

000000020

-  If the process connection is not screwed far enough into the process wall, there is a risk that material will accumulate in front of the device (**A**), thereby damping the microwave signal.
- If, on the other hand, the process connection is screwed too far into the process (**B**), there is a risk of damage occurring as a result of large product items falling.
- When using the G 1½ process connection (standard thread according to ISO 228-1, hexagon SW55) and using the optional counternut, the device can be mounted flush particularly easily, as it is a cylindrical thread.
- Weld-in adapters of type FAR52-A* with G 1½ and 1½ NPT female threads are available as accessories.
- In case of existing deviating female threads in the process wall (R 2 to R 4 or 2 NPT to 4 NPT), additional screw-in adapters of type FAR52-B* are available as accessories.
- Weld-in sleeves G 1 half length according to EN 10241 are also available as accessories.
- Accessories →  25

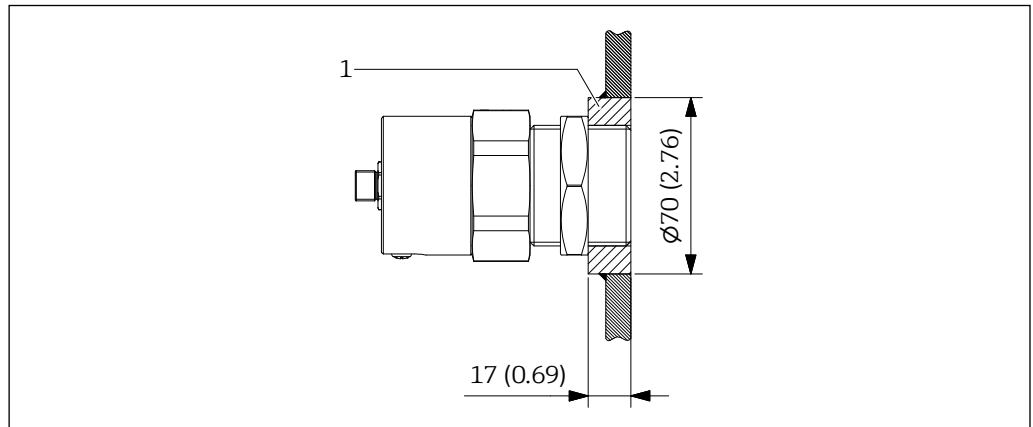

10 Weld-in adapter FAR52. Unit of measurement mm (in)

000000015

1 Weld-in adapter

Mounting samples

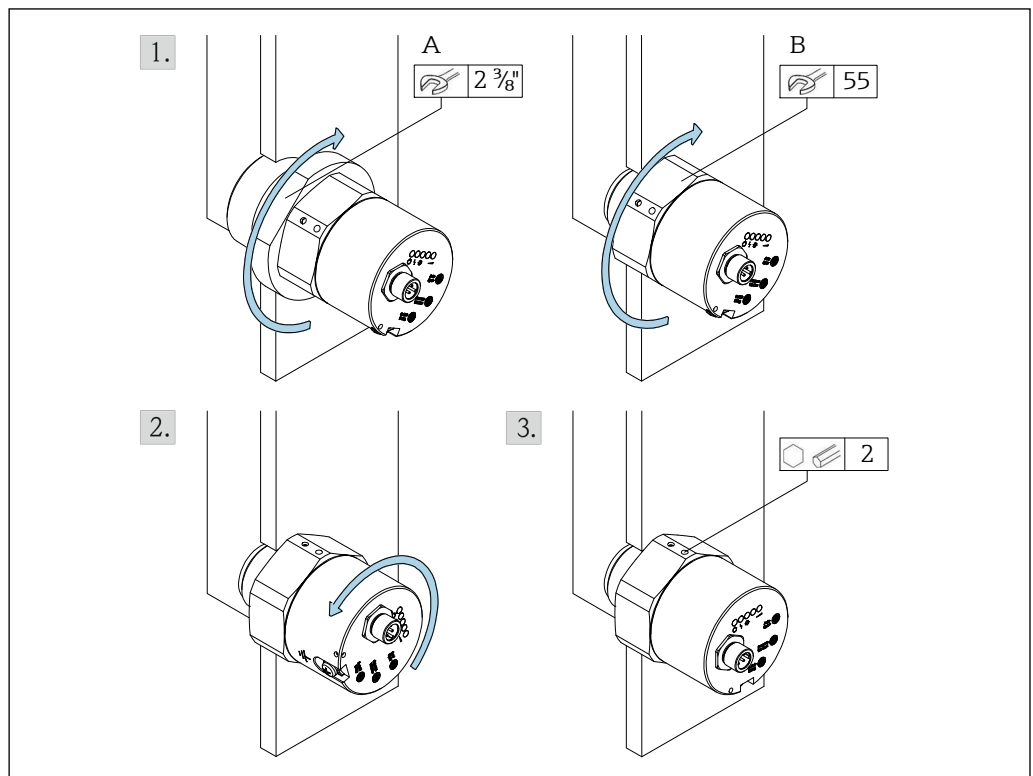

11 Mounting with connection thread

000000061

A 1 1/2 NPT
B G 1 / G 1 1/2

1. Screw in conical (A) or cylindrical (B) connection thread.
2. Align the housing of the electronics (potential equalization terminal of both devices must point in the same direction).
3. Fix the housing in place.

Mounting alternatives

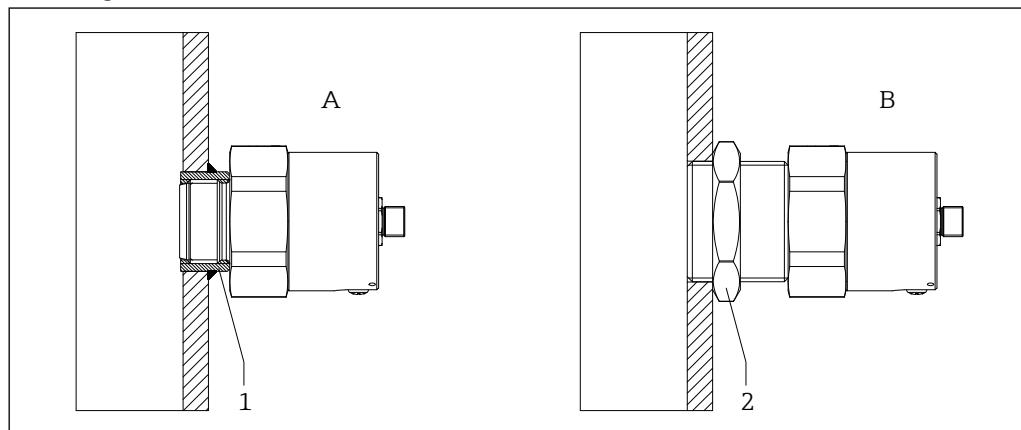

12 Mounting alternatives

- 1 Welding sleeve G 1
2 Counternut G 1½

000000014

- When mounting with welding socket G 1 (A), the device is screwed in as far as it will go.
- When using the G 1½ process connection (B) and using the optional counternut, the device can be mounted flush particularly easily, as it is a cylindrical thread.
- All installation variants are sealed with a suitable sealant (to be provided by the customer).

i Weld-in sleeve and counternuts are available via the ordering structure ("Accessories enclosed" option) and individually as accessories. → 25

Mounting not in contact with the process

The device is mounted in one of the following three ways:

- For a microwave-impermeable process wall (for example, metal vessel wall), mounting is done in front of microwave-permeable windows such as plastic plugs, ceramic disks, or sight glass fittings.
- In the case of a microwave-permeable process wall (for example, plastic container), mounting is carried out directly from the outside on the wall using appropriate adapters (for example, mounting brackets).
- For open processes, the mounting is arbitrary.

Mounting in front of microwave-impermeable process wall

If, due to process conditions (such as high temperatures, high pressures or hazardousness of the material), direct installation in the microwave-impermeable process wall is not possible, it is possible to have the device radiated through an additionally installed plug.

The following materials have been tested and are suitable for radiating through:

- Plastics (virginal, unfilled) such as Polytetrafluoroethylene (PTFE), Polyethylene (PE) or Polypropylene (PP)
- Aluminum oxide ceramics (purity min. 99 %, uncolored)
- Borosilicate glass (uncolored)

- i**
- The maximum temperature **T** at the process connection must be observed. → 19
 - When mounting in front of a microwave-permeable plug and the risk of condensation forming on the inner wall of the process, use a plug (2) that protrudes into the process.
 - The distance **A** depends on the free passage area **D**. Select a distance as small as possible to avoid possible signal attenuation (for example, max. 40 mm (1.57 in) with a passing surface of 50 mm (1.97 in)).
 - Depending on the material, coloring or added (colored) additives can sometimes cause high signal attenuation and are therefore generally unsuitable for this application.
 - Matching plugs made of PTFE or aluminum oxide ceramic of type FAR54 are available in different lengths and diameters as accessories. → 30

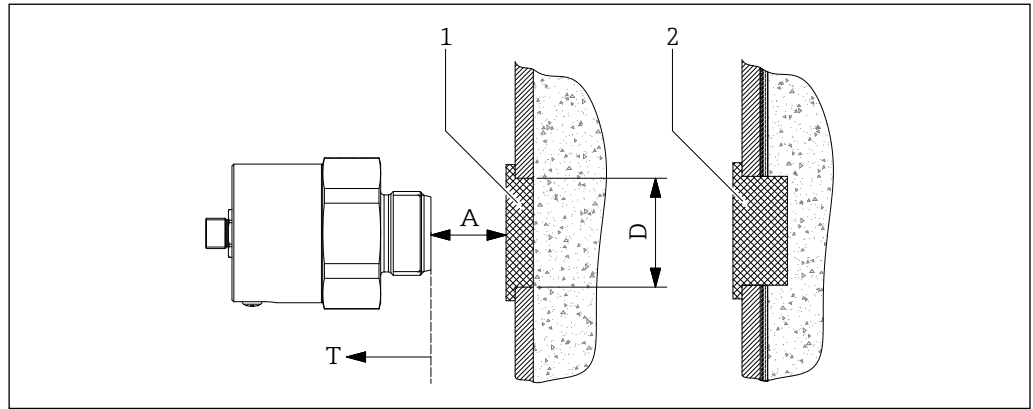



000000021

13 Mounting in front of microwave-impermeable process wall

- 1 Microwave-permeable plug
- 2 Microwave-permeable plug in case of condensate formation on the inner process wall

Mounting in front of microwave permeable sight glass fitting

If the process wall cannot be radiated through, it is also possible to have the device radiated from the outside through a suitable sight glass fitting. The sight glass in these fittings is made of uncolored borosilicate glass.

-  The maximum temperature at the process connection must be observed. → 19
-  The distance **A** depends on the free passage area **D**. Select a distance as small as possible to avoid possible signal attenuation (for example, max. 40 mm (1.57 in) with a passing surface of 50 mm (1.97 in)).

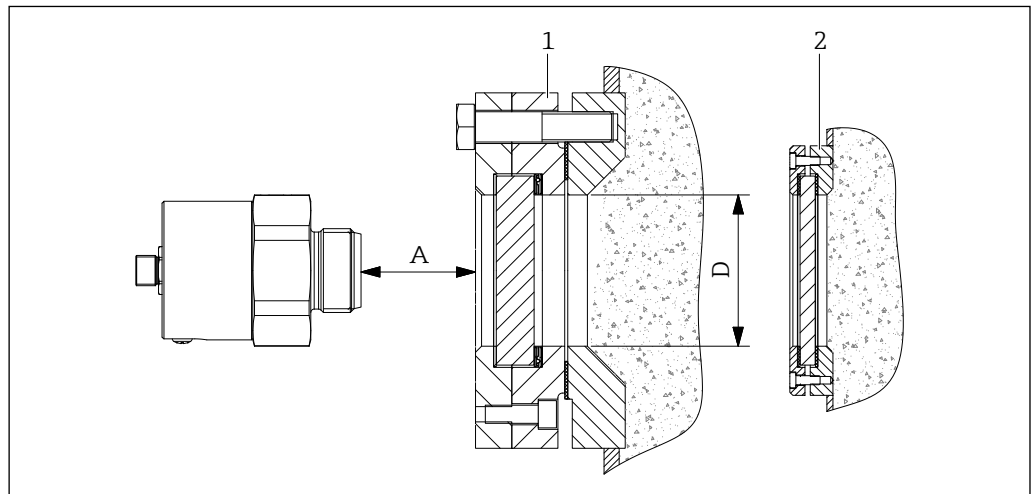

000000023

14 Mounting in front of microwave permeable sight glass fitting

- 1 Sight glass fitting for processes up to 10 bar (145 psi)
- 2 Sight glass fitting for unpressurized processes

Always install sightglasses only in places where no material can accumulate on the process side (risk of incorrect measurements).

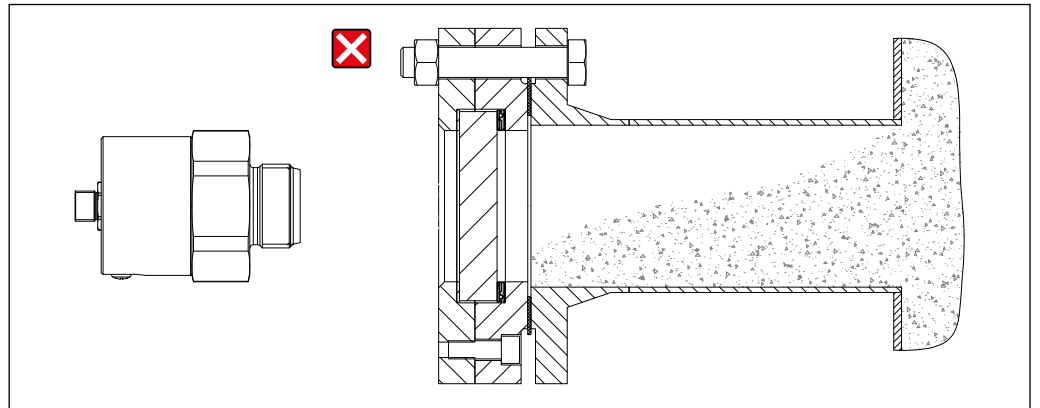

15 Impermissible mounting with the risk of material accumulation

000000024

i Suitable sight glass fittings are available as accessories in various designs. → 31

Mounting on process nozzle

Mounting on a process nozzle offers the following advantages:

- By using existing nozzles, no modifications have to be made to the process.
- The use of suitable plugs prevents material from accumulating in the nozzle.
- At the same time, the plug provides wear protection for the device.
- The assembly or disassembly of the devices can be carried out during operation, which represents a significant simplification in the case of maintenance.

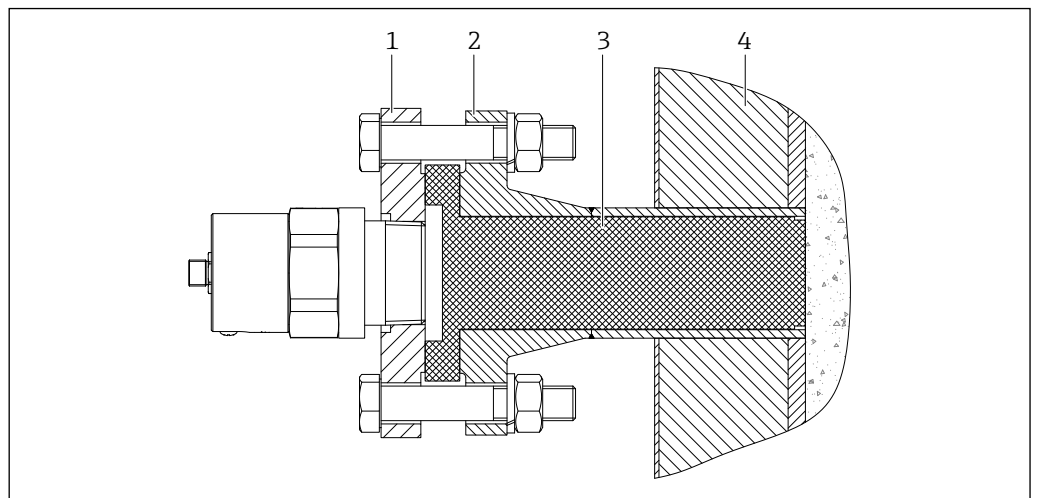

16 Mounting on process nozzle

000000027

- 1 Mounting flange
- 2 Existing process nozzle
- 3 Plug
- 4 Process insulation

- i**
- Suitable mounting flanges with corresponding stainless steel connection threads and plugs made of PTFE or aluminum oxide ceramic for existing process nozzles are available as accessories.
 - Type FAR50 process nozzles consisting of weld-in nozzles, plugs and mounting flanges are available as accessories for the G 1½ device connection thread in various sizes and materials.
 - Accessories → 25

If there is a risk of buildup, avoid assembly methods that could promote this process.

- i
 - In the case of a non-vertical process wall, mount the process nozzle so far into the process that no material can accumulate in front of it (**A**).
 - When mounting the process nozzle and there is a risk of material accumulating on the inner process wall, use a nozzle that protrudes into the process (**B**).
 - The maximum plug length depends on the attenuation and the water absorption of the material; manufacturer's instructions in this respect must be observed.
 - If there is a risk of condensation forming between the process connection of the device and the plug, use the process connection piece type FAR50, this is equipped with a mounting flange with pressure compensation element. → 33

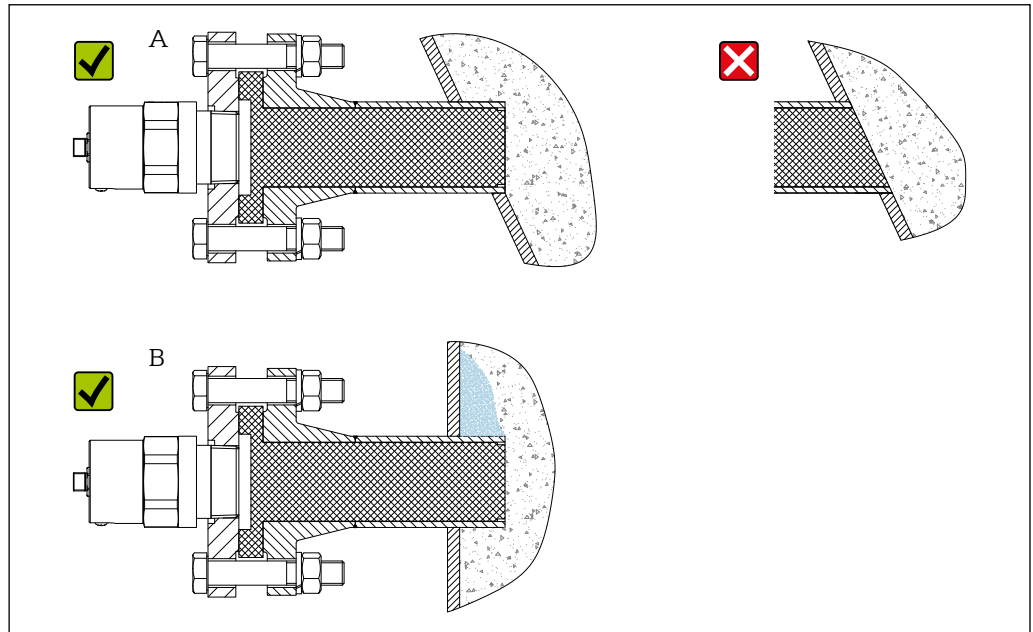

17 Mounting with risk of buildup

000000028

For existing process nozzles, the optionally available plug-in adapters of type FAR51 can be used. These are simply plugged in and fixed, which significantly reduces the mounting effort (also with regard to maintenance).

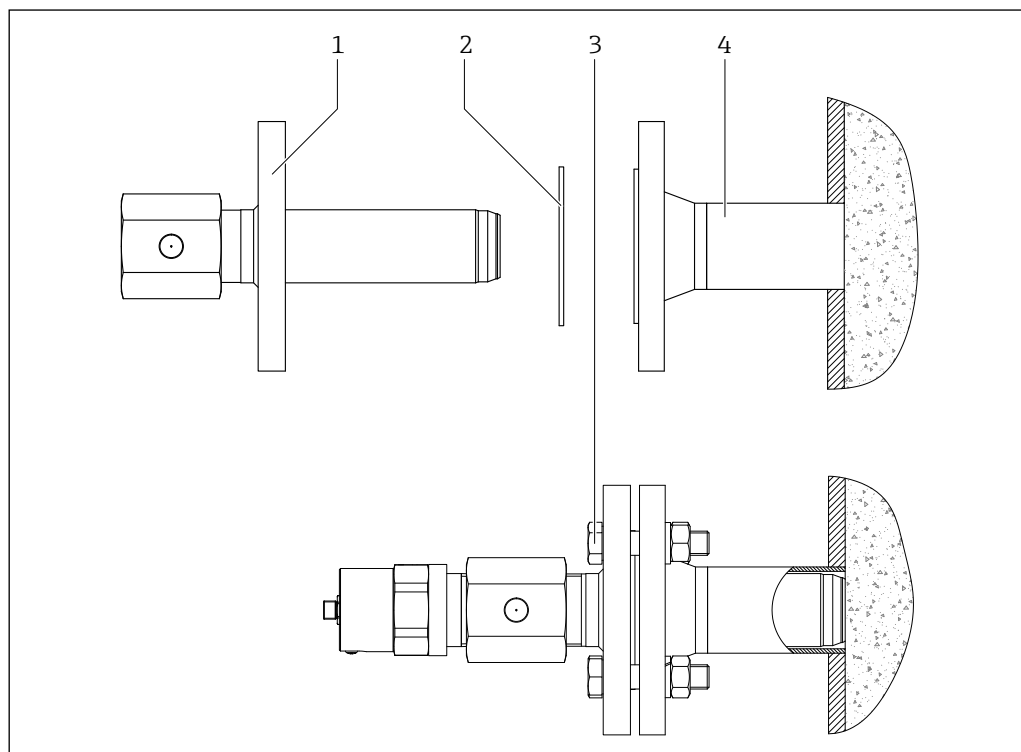

18 Mounting with insertion adapter FAR51

000000029

- 1 Insertion adapter
- 2 Customer-supplied gasket
- 3 Customer-supplied installation material
- 4 Process nozzle

i For process temperatures of +60 to +450 °C (+140 to +842 °F), plug-in adapters for existing process connections of type FAR51 made of stainless steel are available as accessories for the device connection threads G 1½ and 1½ NPT. → 32

Mounting with high pressure adapter

For applications with high process pressure up to 21 bar (305 psi), absolutely use the following high-pressure adapter. → [30](#)

- i** ■ The maximum temperature at the process connection of the FDR16/FQR16 must be observed. → [19](#)
- The high pressure adapter is suitable for the device connection threads G 1½ and 1½ NPT.

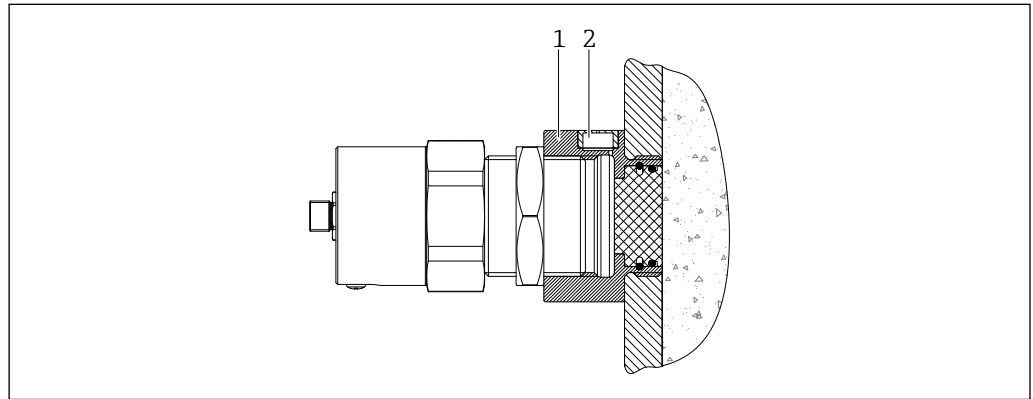

19 Mounting with high pressure adapter

000000026

- 1 High pressure adapter
- 2 Integrated venting element

Mounting with high temperature adapter and extensions

For simple and easily accessible high temperature applications in the range of +60 to +450 °C (+140 to +842 °F), there is a simple adapter for the device connection threads G 1½ and 1½ NPT with flush aluminum oxide ceramic, this can be extended with extensions.

- i** ■ The maximum process pressure of 0.8 to 5.1 bar (12 to 74 psi) absolute at the high temperature adapter must be observed. → [19](#)
- The maximum temperature **T** at the process connection of the device must be observed; exceeding this will lead to destruction.
- **L** must be selected depending on the process and ambient temperatures.
- Suitable high temperature adapters and stainless steel extensions are available as accessories. → [33](#)

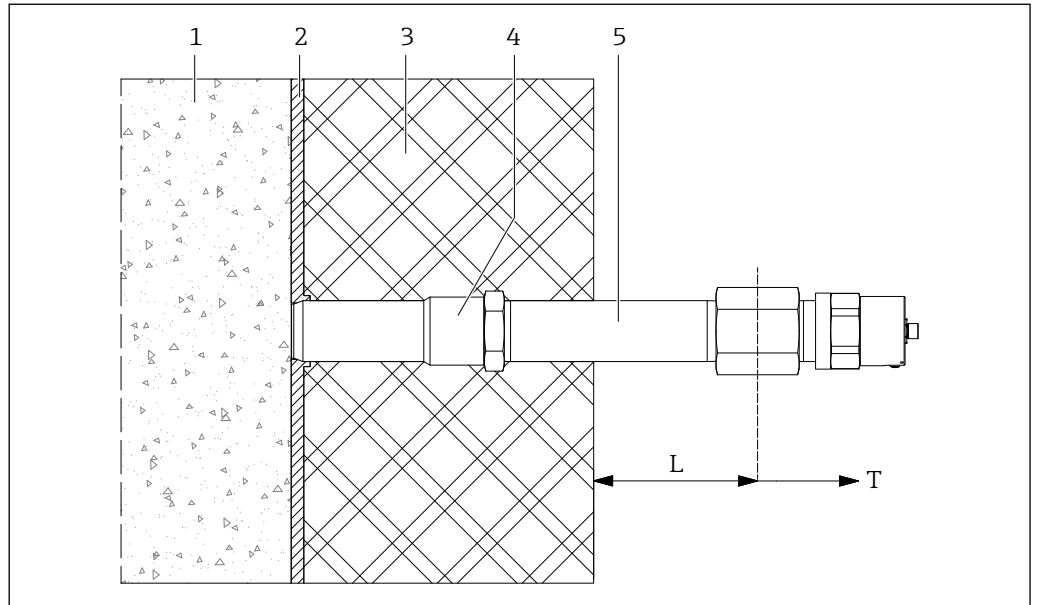

000000031

20 Mounting with high temperature adapter and extensions

- 1 Process
- 2 Wall
- 3 Insulation
- 4 High temperature adapter
- 5 Length extensions (optional)

Mounting for open processes

Mounting in open processes can be done with a simple mounting bracket.

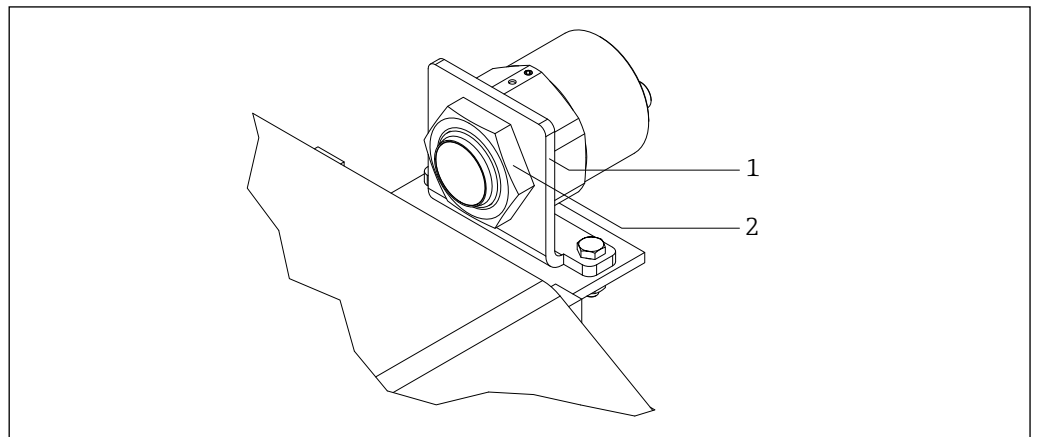

000000019

21 Mounting for open processes

- 1 Mounting bracket
- 2 Counternut

i Counternuts and mounting bracket for G 1 are available individually as accessories. → 27

Environment

Ambient temperature -20 to +60 °C (-4 to +140 °F)

Storage temperature See ambient temperature

Degree of protection	<ul style="list-style-type: none"> ▪ \otimes: IP69 ▪ \triangle: IP67
Vibration resistance	See vibration influence → 8
Electromagnetic compatibility	<ul style="list-style-type: none"> ▪ Interference emission to EN 61326, Electrical Equipment Class B ▪ Interference immunity to EN 61326, Appendix A (Industrial)
Reverse polarity protection	Integrated; No damage in case of reverse polarity or short circuit

Process

Process temperature	<ul style="list-style-type: none"> ▪ -20 to +60 °C (-4 to +140 °F) ▪ -20 to +450 °C (-4 to +842 °F) with optional high temperature adapter ▪ Observe deviating temperature ranges for the accessories offered!
Process pressure	<ul style="list-style-type: none"> ▪ 0.5 to 6.8 bar (7 to 99 psi) absolute, only to be observed for direct process mounting ▪ 0.8 to 5.1 bar (12 to 74 psi) absolute, when using the optional high temperature adapter ▪ 0.5 to 21 bar (7 to 305 psi) absolute, when using the optional high pressure adapter ▪ Observe deviating pressure ranges for the accessories offered!
Vibration	See vibration influence → 8

Mechanical construction

Dimensions

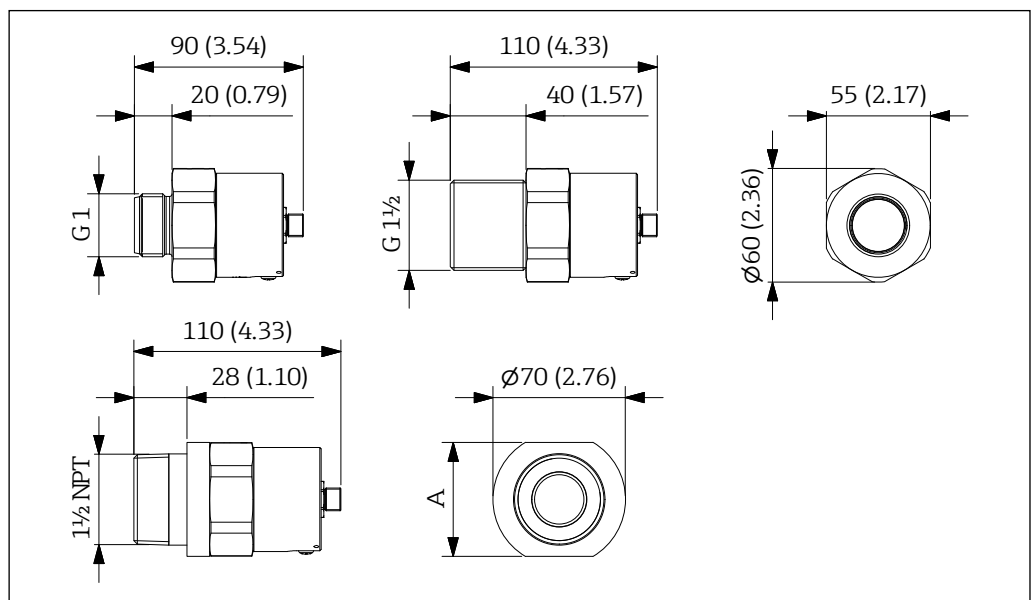

22 Dimensions. Unit of measurement mm (in)

A $2\frac{3}{8}$ " (60.325 mm / 2.375 in)

000000012

Weight	Depending on the selected housing and process connection (max. 1.7 kg (3.75 lb))
---------------	--

Materials

- Stainless steel 316L (1.4404): Housing with process connection
- Brass nickel plated: Connector housing
- PTFE: Transmission windows

Process connection

- Connection thread:
- G 1 and G 1½ according to ISO 228-1
 - 1½ NPT according to ANSI/ASME

Operability

By using frequencies in the 24 GHz range, also products with low attenuation can be detected, even if the product quantities are low. The calibration options for the microwave barrier offer the necessary flexibility to ensure that the devices can be easily adapted to the application:

- Adjustable sensitivity
- Switching delay: off, 500 ms to 10 s
- LED signal strength indicator as adjustment and positioning aid



No settings are required for the FQR16.

Operation concept**Fast and safe commissioning**

The FDR16 is parameterized with the help of the operating magnet. Hereby, among other things, an automatic adjustment to the sensitivity necessary for a clear point level detection of the products takes place. If the microwave signal is sufficiently attenuated, the FDR16 responds with a corresponding output signal.



The operating magnet is included in the scope of delivery of the FDR16. It can be optionally cancelled or ordered as an accessory. →  27

The parameterization is stored internally and is retained even after the supply voltage is removed. No operation is required while the device is working. Adaptation to the application must only be carried out during initial installation. However, subsequent changes can be made and saved at any time.

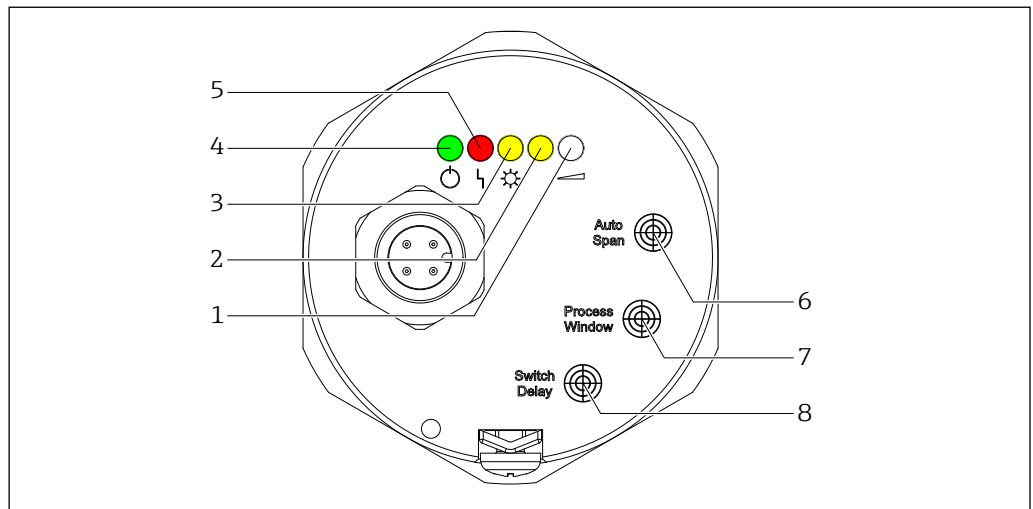

23 Display and operating elements of the FDR16

000000010

- 1 Signal strength (LED white)
- 2 Only for parameterization: LED yellow
- 3 Sensor state (LED yellow)
- 4 Operation (LED green)
- 5 Error/warning (LED red)
- 6 Parameterization point automatic adjustment
- 7 Parameterization point process window
- 8 Parameterization point switch delay

Efficient diagnostic behavior increases the availability of the measurement

- Distinction between recoverable (warning) and unrecoverable faults (error).
- Warnings:
 - Communication with FQR disturbed
 - Adjustment could not be performed successfully
- Errors:
 - Internal hardware error
 - Initialization failed (memory error)
 - Permissible ambient temperature exceeded/fallen below
 - No communication with the FQR16
- In addition to the permanent self-diagnosis, a manual function test can also be performed on the FDR16. → 24

Light signals (LEDs)

Display	Meaning
	Operation LED lights up: Device is ready for operation (supply voltage is applied) LED flashes: Device is in parameterization mode
	Error/Warning LED lights up: Error/device failure (unrecoverable error) LED flashes: Warning/maintenance required (recoverable error)
	Sensor state LED off: Free path LED on: Covered path
	For parameterization only: see operating instructions → 34
	Signal strength The signal strength is indicated by a white LED, the light state (off, 2 to 15 Hz or permanently lit) is proportional to the strength of the signal.

Output signal

The following table shows the behavior of the two antivalent signal outputs in connection with the display of the signal strength when the point level is exceeded or not reached.

Point level	Signal strength (LED white)	Sensor state	Switching output	
			MAX safety	MIN safety
	LED on or flashing fast (approx. 9 to 15 Hz)		1 / 2	1 / 4
	LED off or flashing slowly (approx. 2 to 8 Hz)		1 / 2	1 / 4

The following table shows the behavior of the two signal outputs in the event of an error.

Point level	Sensor state	Error/Warning	Switching output	
		Warning 	1 / 2	1 / 4
		LED flashing	1 / 2	1 / 4
		Error 	1 / 2	1 / 4
		LED lights up permanently		

On-site operation

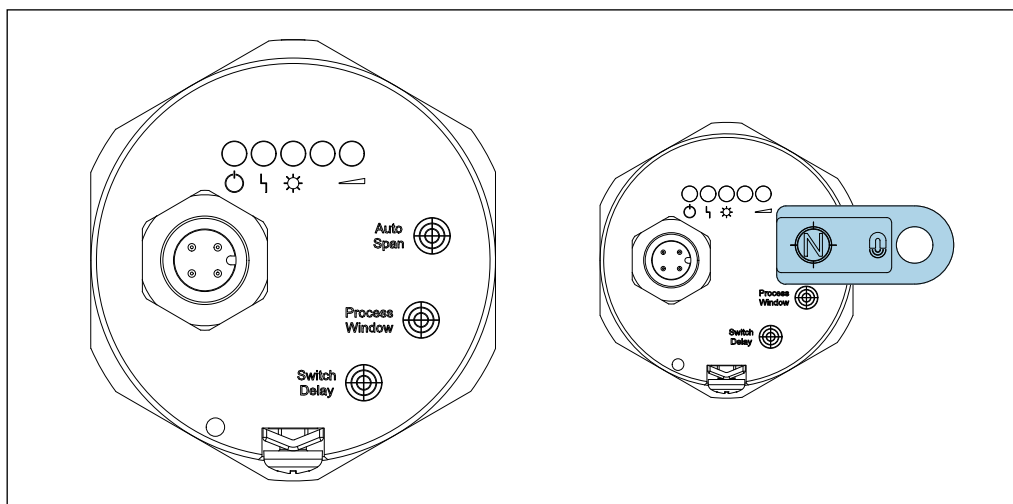

24 On-site operation

000000011

To operate, place the operating magnet (north pole visible as shown) on the marked areas of the FDR16.

The following parameterization functions are available:

- Automatic adjustment
- Process window
- Switching delay
- Reset

- i
 - Activation of the parameterization mode with an operating magnet applied to one of the markings ("Auto Span", "Process Window" or "Switch Delay").
 - If no action is taken within 10 minutes, the parameterization mode is terminated. The device switches to normal operation.
 - The device continues to operate normally in the background depending on the current settings, so that, for example, exceeding the point level leads to a switchover of the signal output.
 - For details see Operating Instructions → 34

Function test	<ul style="list-style-type: none"> ▪ An internal function test can be triggered with the aid of the operating magnet. ▪ For details see Operating Instructions →  34
----------------------	---

Certificates and approvals

CE mark	The Soliwave microwave barrier meets the legal requirements of the applicable EU guidelines. These are listed in the corresponding EU Declaration of Conformity, together with the applied standards. By applying the CE mark, Endress+Hauser confirms that the device has passed the necessary tests.
Ex approval	All explosion protection data is listed in separate documentation which is available from the download area. The Ex documentation is supplied as standard with all Ex-systems.
RoHS	The microwave barrier complies with the substance restrictions of the Restrictions on Hazardous Substances Directive 2011/65/EU and the Delegated Directive 2015/863/EU.
Telecommunications	EN 300440 Short range radio devices (SRD) – radio devices for operation in a frequency range of 1 GHz to 40 GHz
Food suitability	The materials in contact with the process meet the requirements of EU Regulation 1935/2004 and 2023/2006.

Ordering information

Detailed ordering information is available from the following sources:

- In the Product Configurator on the Endress+Hauser website: www.endress.com → Click "Corporate" → Select your country → Click "Products" → Select the product using the filters and search field → Open product page → The "Configure" button to the right of the product image opens the Product Configurator.
- Endress+Hauser sales center: www.addresses.endress.com



Product Configurator – the tool for individual product configuration

- Up-to-the-minute configuration data
- Depending on the device: Direct input of measuring point-specific information such as measuring range or operating language
- Automatic verification of exclusion criteria
- Automatic creation of the order code and its breakdown in PDF or Excel output format

TAG	<p>Measuring point (tag) (TAG)</p> <p>The device can be ordered with a tag name.</p> <p>Position of the tag name</p> <p>In the additional specification, select:</p> <ul style="list-style-type: none"> ▪ Tag plate, stainless steel ▪ Plastic film ▪ Supplied plate <p>Definition of the tag name</p> <p>In the additional specification, specify: 3 lines, each containing up to maximum 18 characters The specified tag name appears on the selected label.</p>
------------	--

Scope of delivery The scope of delivery includes the FDR16 or FQR16 in a box with Brief Operating Instructions included.

Preset switching delay When ordering an FDR16 with the extended order option "Preset time delay", this will be preset during manufacturing according to customer requirements.

Accessories

Various accessories are available for the device, and can be ordered with the device or at a later stage from Endress+Hauser. Detailed information on the order code in question is available from your local Endress+Hauser sales center or on the product page of the Endress+Hauser website: www.endress.com.

Prefabricated cables

- Connection cable with M12 right-angle plug (☒)
- Number of poles/cross section: 4 x 0.34 mm²
- A-coded
- Operating temperature range: -25 to +90 °C (-13 to +194 °F)
- Materials:
 - TPU (housing)
 - FKM (seal)
 - PUR (cable)
- Protection: IP69
- Order number:
 - 71530954 (5 m (196.85 in))
 - 71530958 (10 m (393.70 in))
 - 71530962 (20 m (787.40 in))
- Connection cable with M12 right-angle plug (△/☒)
- Number of poles/cross section: 4 x 0.34 mm²
- A-coded
- Operating temperature range: -20 to +60 °C (-4 to +140 °F)
- Materials:
 - TPU (housing)
 - FKM (seal)
 - PUR (cable)
- Protection: IP67 (△) / IP69 (☒)
- Order number:
 - 71530974 (5 m (196.85 in))
 - 71530975 (10 m (393.70 in))

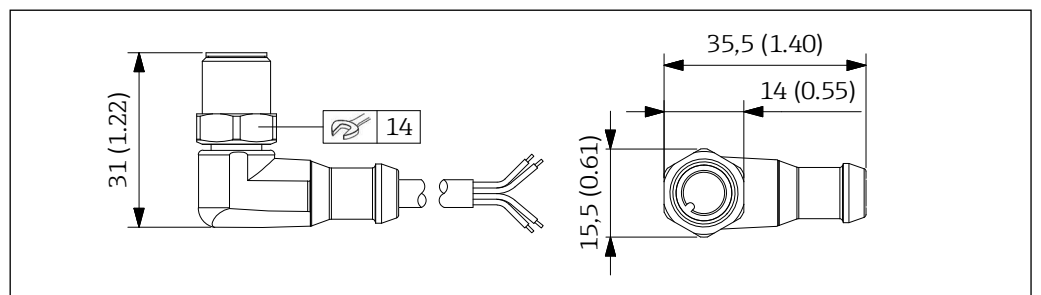

☒25 Connection cable with M12 right-angle plug. Unit of measurement mm (in)

000000134

- Connection cable with M12 right-angle socket (☒)
- Number of poles/cross section: 4 x 0.34 mm²
- A-coded
- Operating temperature range: -25 to +90 °C (-13 to +194 °F)
- Materials:
 - TPU (housing)
 - FKM (seal)
 - PUR (cable)
- Protection: IP69
- Order number:
 - 71530949 (5 m (196.85 in))
 - 71530950 (10 m (393.70 in))
 - 71530953 (20 m (787.40 in))

- Connection cable with M12 right-angle socket (△/☒)
- Number of poles/cross section: 4 x 0.34 mm²
- A-coded
- Operating temperature range: -20 to +60 °C (-4 to +140 °F)
- Materials:
 - TPU (housing)
 - FKM (seal)
 - PUR (cable)
- Protection: IP67 (△) / IP69 (☒)
- Order number:
 - 71530971 (5 m (196.85 in))
 - 71530973 (10 m (393.70 in))

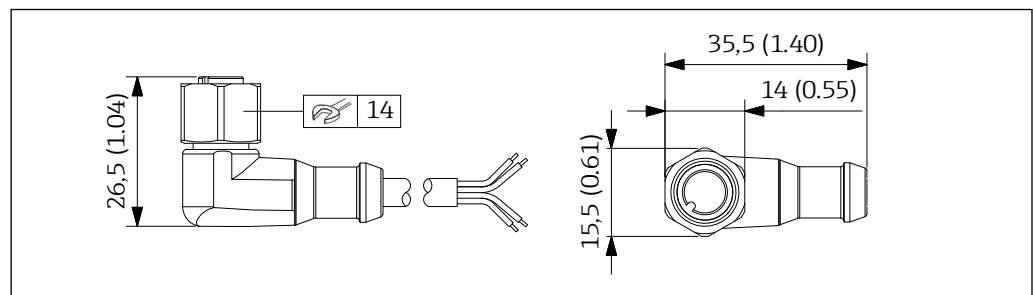

☒26 Connection cable with M12 right-angle socket. Unit of measurement mm (in)

0000000133

- Connecting cable with M12 right-angle plug and M12 right-angle socket (☒)
- Number of poles/cross section: 4 x 0.34 mm²
- A-coded
- Operating temperature range: -25 to +90 °C (-13 to +194 °F)
- Materials:
 - TPU (housing)
 - FKM (seal)
 - PUR (cable)
- Protection: IP69
- Order number:
 - 71530943 (5 m (196.85 in))
 - 71530944 (10 m (393.70 in))
 - 71530947 (20 m (787.40 in))

- Connecting cable with M12 right-angle plug and M12 right-angle socket (△/☒)
- Number of poles/cross section: 4 x 0.34 mm²
- A-coded
- Operating temperature range: -20 to +60 °C (-4 to +140 °F)
- Materials:
 - TPU (housing)
 - FKM (seal)
 - PUR (cable)
- Protection: IP67 (△) / IP69 (☒)
- Order number:
 - 71530969 (5 m (196.85 in))
 - 71530970 (10 m (393.70 in))

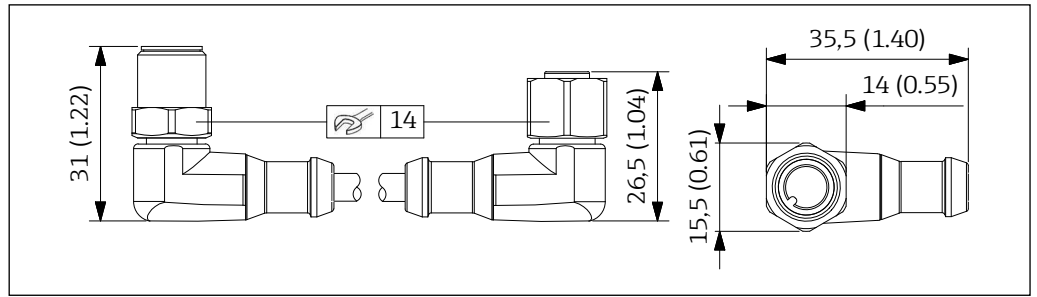

000000135
 27 Connecting cable with M12 right-angle plug and M12 right-angle socket. Unit of measurement mm (in)

Operating magnet

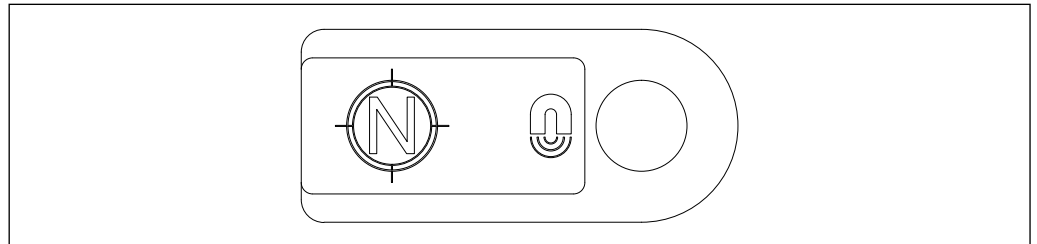

000000132
 28 Operating magnet

Order number: 71535426

Counternut

- Material: 316 (1.4401)
- Weight
 - G1: 0.04 kg (0.09 lb)
 - G 1½: 0.07 kg (0.15 lb)
- Order number:
 - 71530854 (G 1, SW40)
 - 71530857 (G 1½, SW55)

Mounting bracket

- Material: 304 (1.4301)
- Weight: 0.22 kg (0.49 lb)
- Mounting screws (2 x M6): to be provided by customer
- Order number: 71530850

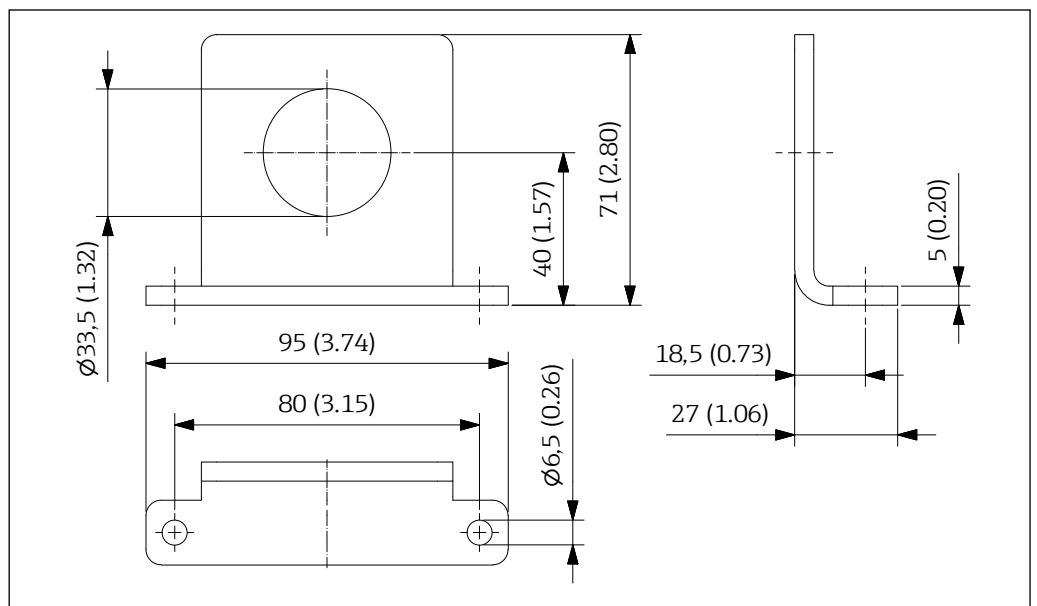

000000037
 29 Dimensions mounting bracket. Unit of measurement mm (in)

Welding sleeve

- G 1 (ISO 228-1), half length according to EN 10241
- Material: 316Ti (1.4571)
- Weight: 0.07 kg (0.15 lb)
- Order number:
 - 71530862
 - 71530941 (with inspection certificate EN 10204 - 3.1 material)

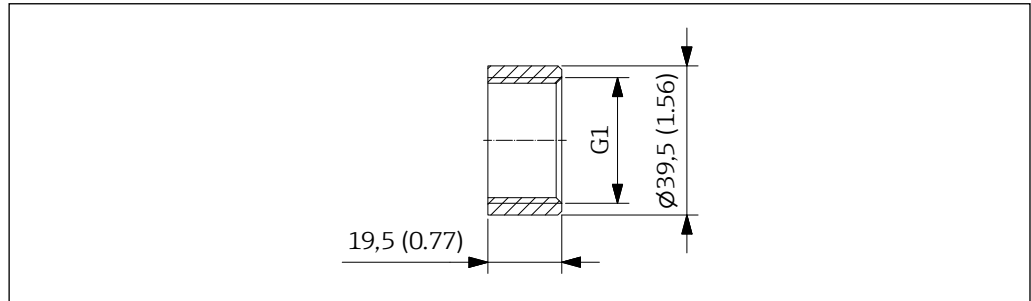

30 Dimensions welding sleeve. Unit of measurement mm (in)

000000036

Weld-in adapter

- Type FAR52 → TI01369F, internal thread G 1½
- Material: 316Ti (1.4571), steel P235GH (1.0345)
- Weight: 0.3 kg (0.66 lb)

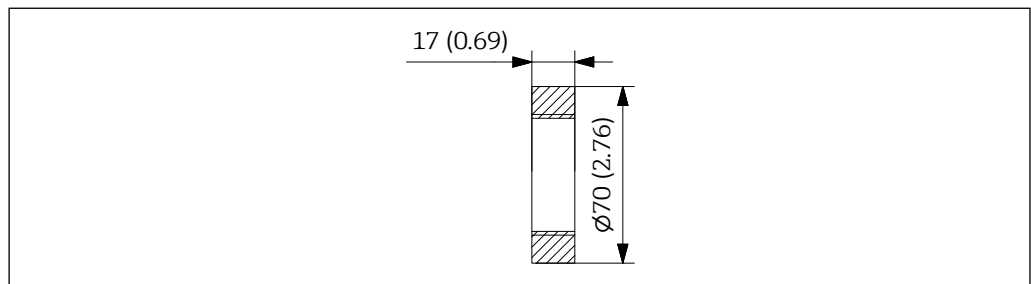

31 Dimensions weld-in adapter FAR52. Unit of measurement mm (in)

000000138

Mounting flange

- Connection dimensions according to DIN EN 1092-1
- Material: 316Ti (1.4571)
- Weight: DN40 approx. 2.3 kg (5.07 lb) to DN100 approx. 5.8 kg (12.79 lb)
- Mounting screws and gasket: to be provided by customer
- Order number:
 - 71530977 (DN40 PN40, G 1)
 - 71530992 (DN40 PN40, G 1, with inspection certificate EN 10204 - 3.1 material)
 - 71381884 (DN40 PN16, G 1½)
 - 71381885 (DN40 PN16, G 1½, with inspection certificate EN 10204 - 3.1 material)
 - 71531009 (DN50 PN16, G 1)
 - 71531011 (DN50 PN16, G 1, with inspection certificate EN 10204 - 3.1 material)
 - 71381887 (DN50 PN16, G 1½)
 - 71381888 (DN50 PN16, G 1½, with inspection certificate EN 10204 - 3.1 material)
 - 71531014 (DN100 PN16, G 1)
 - 71531024 (DN100 PN16, G 1, with inspection certificate EN 10204 - 3.1 material)
 - 71381890 (DN100 PN16, G 1½)
 - 71381891 (DN100 PN16, G 1½, with inspection certificate EN 10204 - 3.1 material)

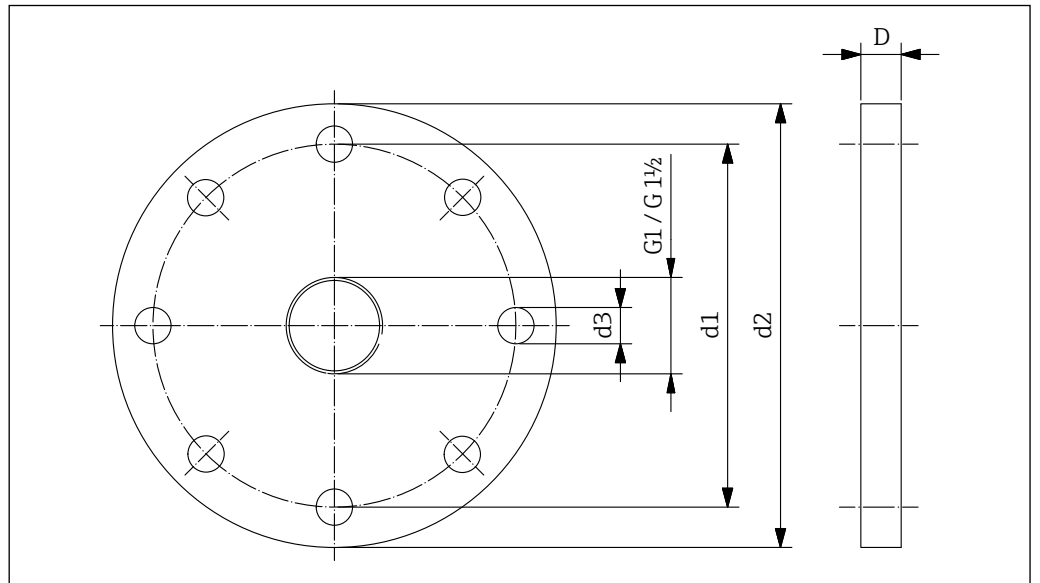

000000038

32 Dimensions mounting flange (Connection dimensions according to DIN EN 1092-1)

Flange	d1 mm (in)	d2 mm (in)	d3 mm (in)	D mm (in)	Holes
DN40 PN40	110 (4.33)	150 (5.91)	18 (0.71)	18 (0.71)	4
DN50 PN16	125 (4.92)	165 (6.50)	18 (0.71)	18 (0.71)	4
DN100 PN16	180 (7.09)	220 (8.66)	18 (0.71)	20 (0.79)	8

- Connection dimensions according to ANSI/ASME B16.5
- Material: 316Ti (1.4571)
- Weight: 1½" approx. 1.5 kg (3.31 lb) to 4" approx. 6.8 kg (15.0 lb)
- Mounting screws and gasket: to be provided by customer
- Order number:
 - 71006349 (1½" 150 lbs, 1½ NPT)
 - 71108387 (1½" 150 lbs, 1½ NPT, with inspection certificate EN 10204 - 3.1 material)
 - 71006351 (2" 150 lbs, 1½ NPT)
 - 71108389 (2" 150 lbs, 1½ NPT, with inspection certificate EN 10204 - 3.1 material)
 - 71006353 (4" 150 lbs, 1½ NPT)
 - 71108391 (4" 150 lbs, 1½ NPT, with inspection certificate EN 10204 - 3.1 material)

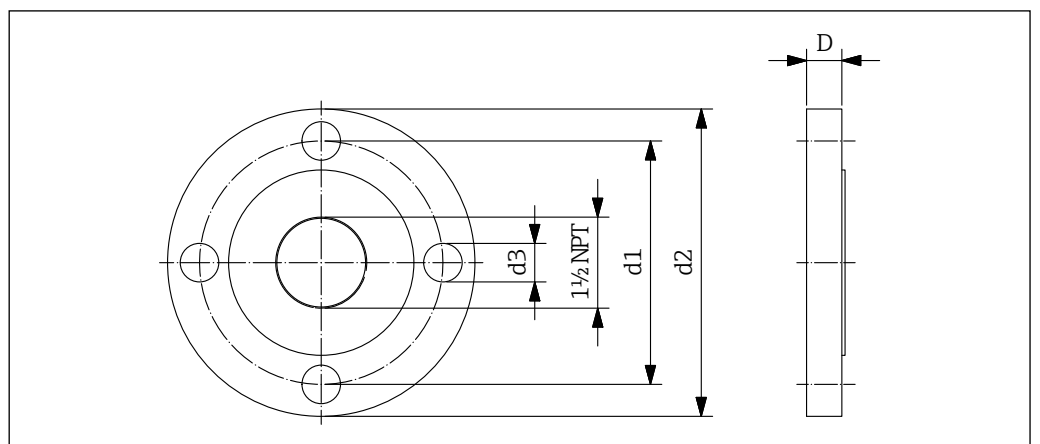

000000039

33 Dimensions mounting flange (Connection dimensions according to ANSI/ASME B16.5)

Flange	d1 mm (in)	d2 mm (in)	d3 mm (in)	D mm (in)	Holes
1½" 150 lbs	98.6 (3.88)	127 (5.00)	15.7 (0.62)	17.5 (0.69)	4
2" 150 lbs	120.7 (4.75)	152.4 (6.00)	19.1 (0.75)	19.1 (0.75)	4
4" 150 lbs	190.5 (7.50)	228.6 (9.00)	19.1 (0.75)	23.9 (0.94)	8

High pressure adapter

- Process pressure: 21 bar (305 psi) absolute
- Material: 316Ti (1.4571), PTFE (window transmission)
- Weight: approx. 0.8 kg (1.76 lb)
- Seal: to be provided by the customer
- Order number:
 - 71381894 (G 1½ (A+B), ISO 228-1)
 - 71381898 (G 1½ (A+B), ISO 228-1, with inspection certificate EN 10204 - 3.1 material)
 - 71381899 (G 1½ (B), ISO 228-1, 1½ NPT (A), ANSI/ASME)
 - 71381904 (G 1½ (B), ISO 228-1, 1½ NPT (A), ANSI/ASME, with inspection certificate EN 10204 - 3.1 material)

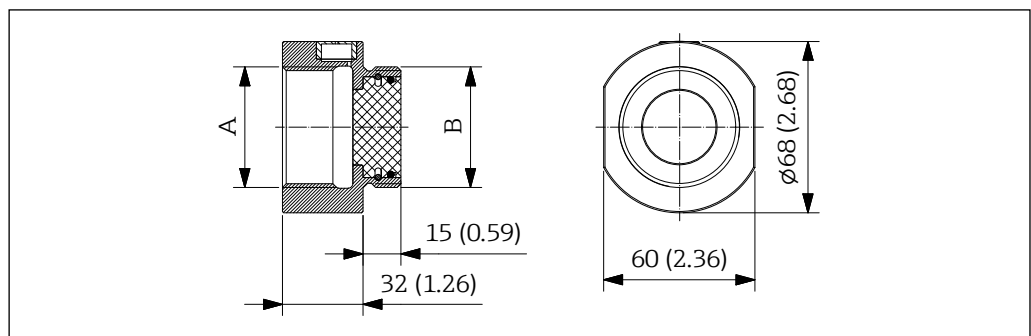

34 Dimensions high pressure adapter. Unit of measurement mm (in)

000000136

- A Device connection thread
B Process connection thread

Plug

- Type FAR54 → TI01371F
- Material: PTFE, aluminum oxide ceramics
- Process temperature: -40 to +800 °C (-40 to +1472 °F)
- Weight: Depending on version (max. 3.2 kg (7.05 lb))

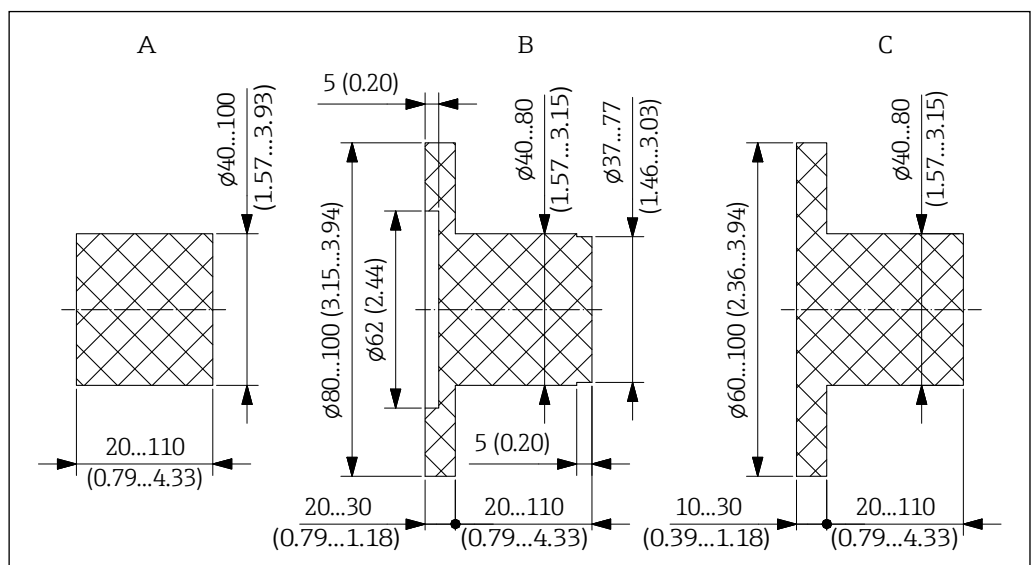

35 Dimensions plug FAR54. Unit of measurement mm (in)

000000041

Sight glass fitting

- Unpressurized, weld-on or weld-in type
- Material: 316Ti (1.4571), seal silicone (max. +200 °C/+392 °F)
- Weight: DN50 approx. 2.4 kg (5.29 lb) to DN100 approx. 4.1 kg (9.04 lb)
- Mounting screws enclosed
- Order number:
 - 71026443 (DN50)
 - 71026444 (DN80)
 - 71026445 (DN100)
- Sight glass disc (spare part)
 - 71209118 (DN50)
 - 71209116 (DN80)
 - 71209115 (DN100)

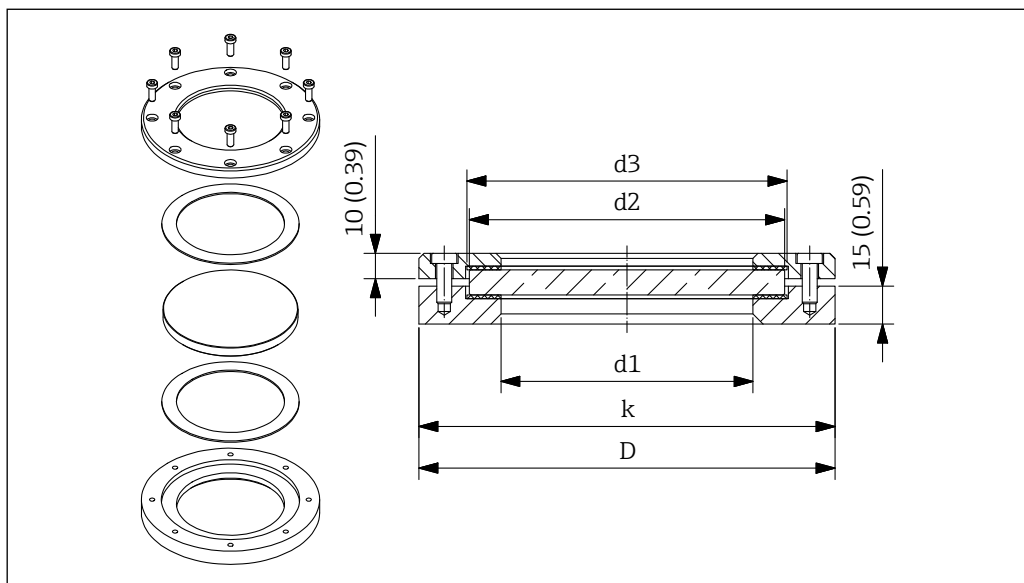

36 Dimensions sight glass fitting for unpressurized processes. Unit of measurement mm (in)

000000042

DN	d1 mm (in)	d2 mm (in)	d3 mm (in)	D mm (in)	k mm (in)
50	80 (3.15)	100 (3.94)	102 (4.02)	140 (5.51)	120 (4.72)
80	100 (3.94)	125 (4.92)	127 (5.00)	165 (6.50)	145 (5.71)
100	125 (4.92)	150 (5.91)	152 (5.98)	190 (7.48)	170 (6.69)

- Process pressure: 10 bar (145 psi) absolute, weld-on or weld-in type
- Material: 316Ti (1.4571), seal KLINGERSIL® C-4400 (max. +200 °C/+392 °F)
- Weight: DN50 approx. 6.7 kg (14.77 lb) to DN100 approx. 13.0 kg (28.66 lb)
- Mounting screws enclosed
- Order number:
 - 71026446 (DN50)
 - 71026447 (DN80)
 - 71026448 (DN100)
- Sight glass disc (spare part)
 - 71209114 (DN50)
 - 71209111 (DN80)
 - 71209107 (DN100)

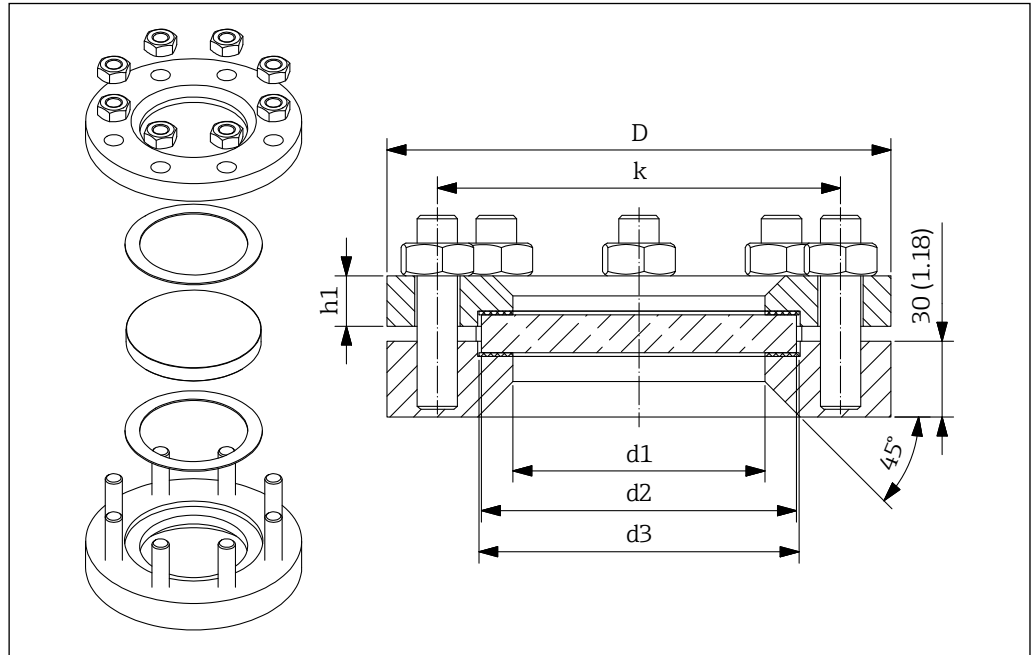

37 Dimensions sight glass fitting for processes up to 10 bar (145 psi). Unit of measurement mm (in)

000000043

DN	d1 mm (in)	d2 mm (in)	d3 mm (in)	D mm (in)	k mm (in)	h1 mm (in)
50	80 (3.15)	100 (3.94)	102 (4.02)	165 (6.50)	125 (4.92)	16 (0.63)
80	100 (3.94)	125 (4.92)	127 (5.00)	200 (7.87)	160 (6.30)	20 (0.79)
100	125 (4.92)	150 (5.91)	152 (5.98)	220 (8.66)	180 (7.09)	22 (0.87)

Insertion adapter

- Type FAR51 → TI01368F
- Process nozzle
 - DN50 to DN100, PN16, Form A
 - NPS 2" to 4" 150 lbs, RF
- Nozzle length: 100 to 300 mm (3.94 to 11.81 in)
- Connection thread 1½ NPT, G 1½
- Optionally with PTFE or aluminum oxide ceramics
- Process temperature: -40 to +450 °C (-40 to +842 °F)
- Process pressure: 0.8 to 5.1 bar (12 to 74 psi) absolute
- Material: 316Ti (1.4571)
- Weight: 5 to 10 kg (11 to 22 lb)

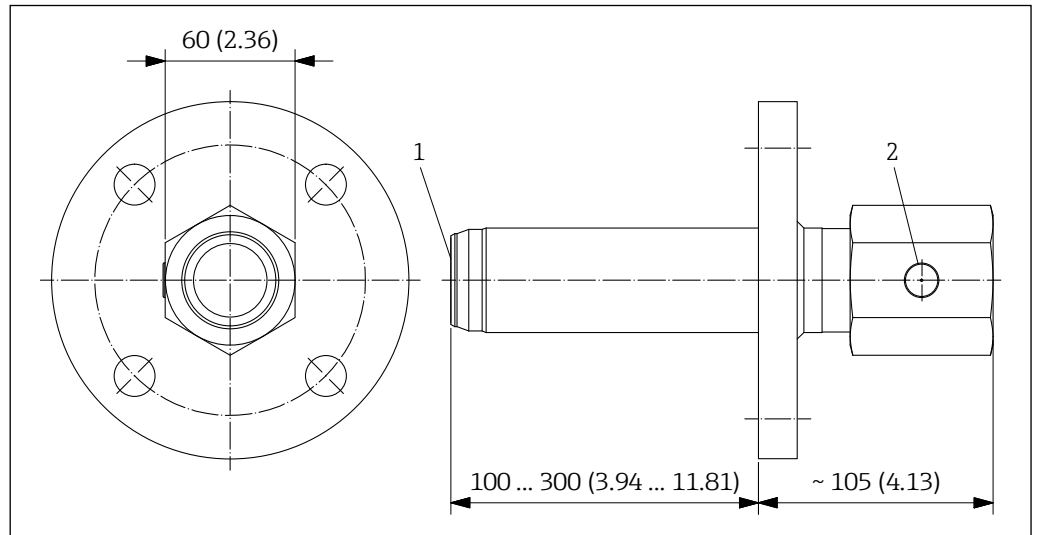

38 Dimensions insertion adapter. Unit of measurement mm (in)

000000045

- 1 Disc with seal, optional
- 2 Integrated venting element

Weld-in nozzle

- Type FAR50 → TI01362F
- Process nozzle:
 - DN50 to DN100, PN16, Form A
 - NPS 2" to 4" 150 lbs, RF
- Nozzle length: 100 to 300 mm (3.94 to 11.81 in)
- Connection thread 1½ NPT, G 1½
- Process temperature: max. -40 to +200 °C (-40 to +392 °F)
- Material: Stainless steel 316Ti (1.4571)
- Weight: approx. 6 to 7 kg (13 to 15.5 lb)
- Mounting screws enclosed

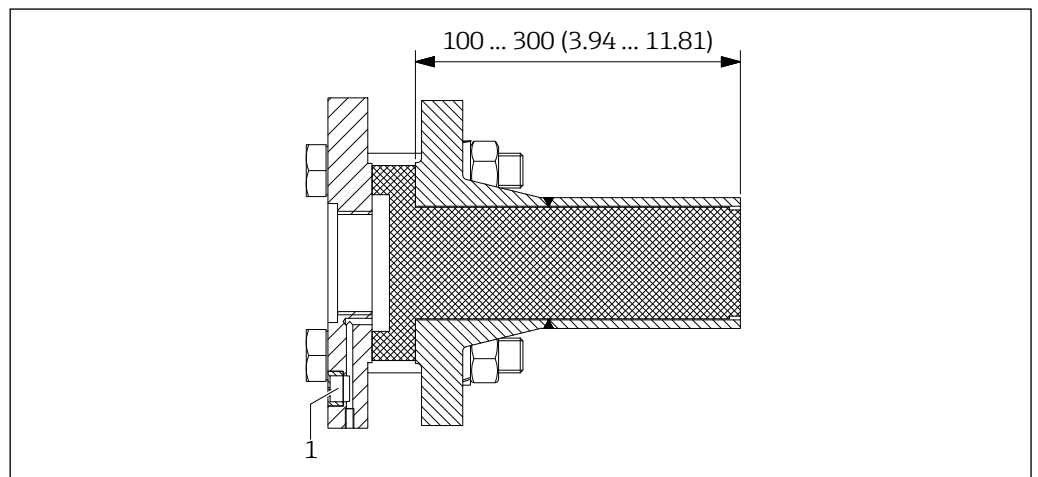

39 Dimensions weld-in nozzle. Unit of measurement mm (in)

000000137

- 1 Integrated venting element

High temperature adapter with extension

- Process temperature: max. +450 °C (+842 °F)
- SW55
- Material: 316Ti (1.4571), aluminum oxide ceramics (front-flush disc)
- Weight: approx. 1.4 kg (3.09 lb)
- Seal: to be provided by the customer
- Order number:
 - 71113441 (R 1½ (A), G 1½ (B))
 - 71478114 ((R 1½ (A), G 1½ (B), with inspection certificate EN 10204 - 3.1 material)
 - 71113449 (1½ NPT (A+B))
 - 71478115 (1½ NPT (A+B), with inspection certificate EN 10204 - 3.1 material)

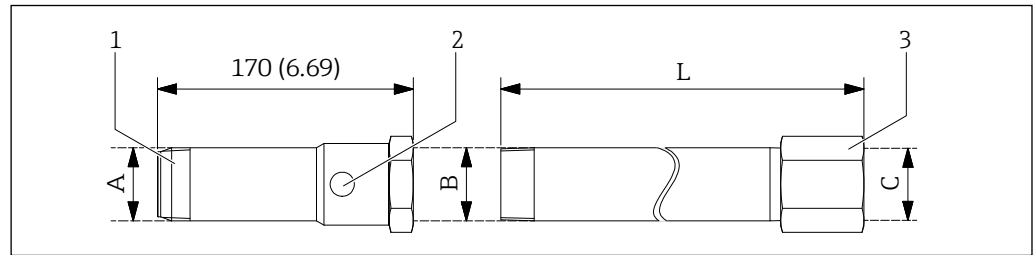

40 Dimensions high temperature adapter with extension. Unit of measurement mm (in)

000000139

- 1 High temperature adapter (connection thread A, internal thread B)
- 2 Integrated venting element
- 3 Extension (connecting thread B, female thread C)

- Extension for high temperature adapter, SW55
- Material: 316Ti (1.4571)
- Weight: 225 mm (8.86 in) approx. 1.1 kg (2.43 lb) to 525 mm (20.67 in) approx. 2.2 kg (4.85 lb)
- Seal: to be provided by the customer
- Order number:
 - 71113450 (R 1½ (B), G 1½ (C), L = 225 mm (8.86 in))
 - 71113451 (R 1½ (B), G 1½ (C), L = 325 mm (12.80 in))
 - 71113452 (R 1½ (B), G 1½ (C), L = 525 mm (20.67 in))
 - 71113453 (1½ NPT (A+B), L = 225 mm (8.86 in))
 - 71113454 (1½ NPT (A+B), L = 325 mm (12.80 in))
 - 71113455 (1½ NPT (A+B), L = 525 mm (20.67 in))

Supplementary documentation

- i** The certificates and approvals currently available can be accessed via the
- Product Configurator
 - Endress+Hauser website: www.endress.com → Downloads.

Device-dependent supplementary documentation

Document type: Operating Instructions (BA)

Installation and initial commissioning – contains all functions in the operating menu that are required for a typical measuring task. Functions beyond this scope are not included.
BA01901F

Document type: Brief Operating Instructions (KA)

Quick guide to the first measured value – includes all essential information from the incoming acceptance to the electrical connection.
KA01535F

Document type: Safety Instructions, certificates

Depending on the approval, Safety Instructions are also supplied with the device, e. g. XA. This documentation is an integral part of the Operating Instructions.
The nameplate indicates the Safety Instructions (XA) that are relevant to the device.

中国E+H技术销售 www.ainstru.com
电话：18923830905
邮箱： sales@ainstru.com
